

FIRAT

SLIDING SYSTEM

70-75

TECHNICAL

CATALOGUE

SLIDING SYSTEMS 70-75



04 Main Profiles

05 Detail Profiles

06 Auxiliary Profiles

07 Glass Bead Applications

08 Sash Closing Uses

11 Reinforcements

12 Detail Profile Applications

19 Window Sections

41 Detail Profile Applications

42 Window Sections

43 Water Drain Channels





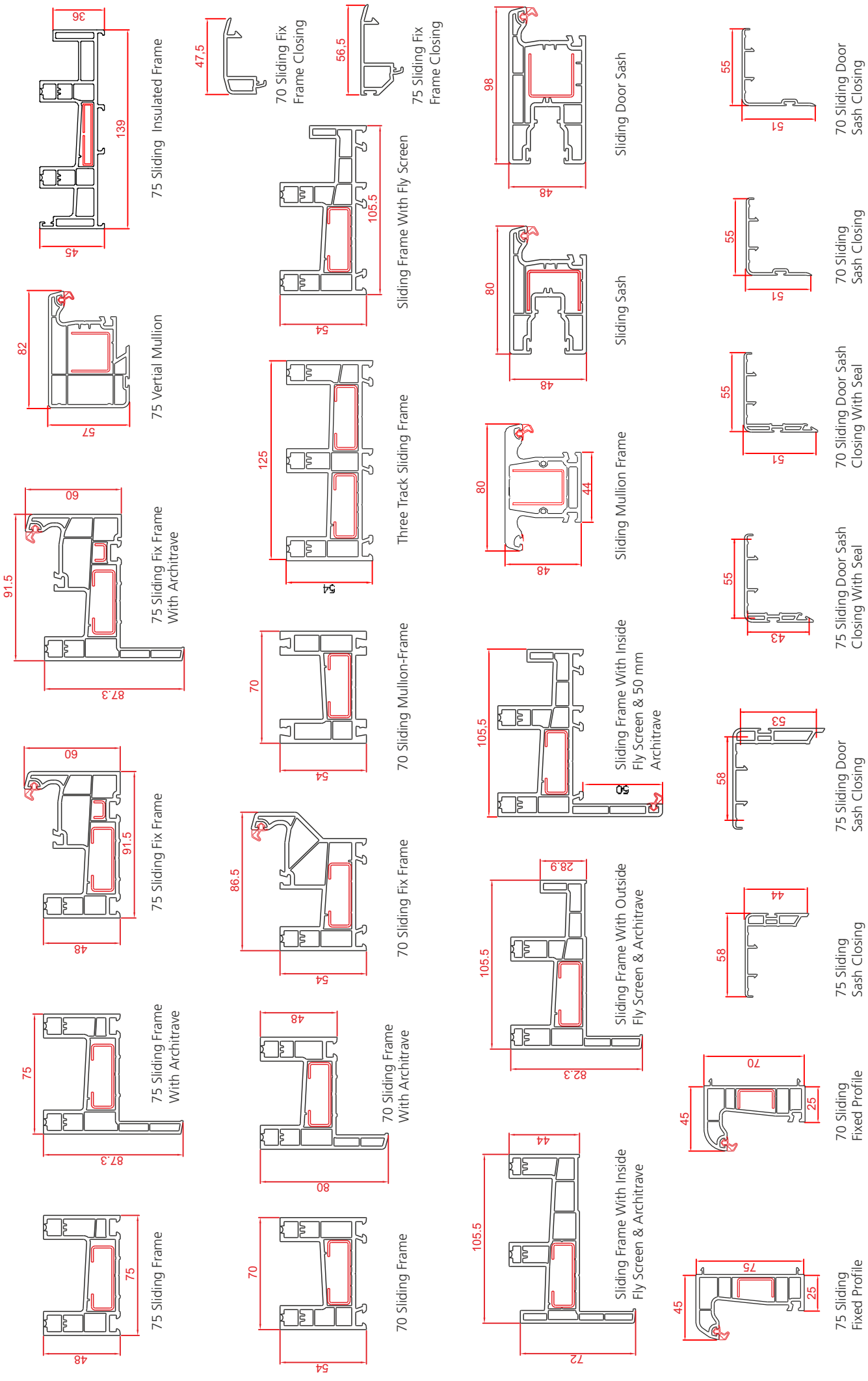





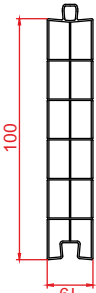

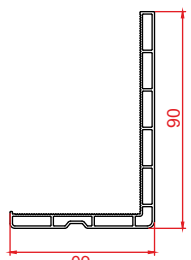
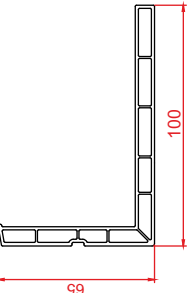

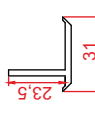

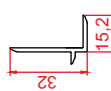

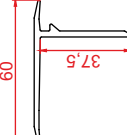
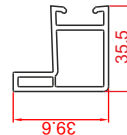
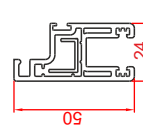
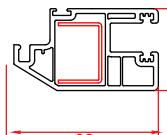
44 Preparation of Handle Hole

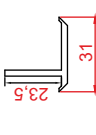
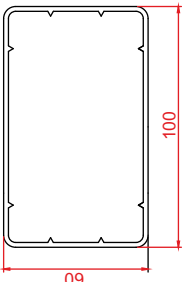
45 Welding

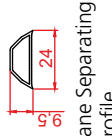
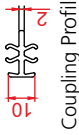

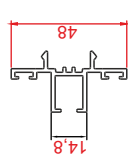
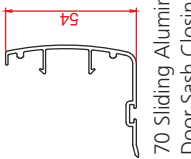
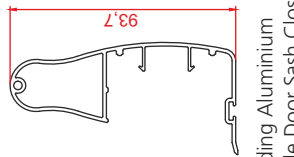
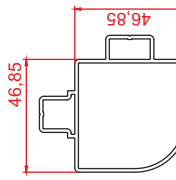
SLIDING SYSTEMS 70-75

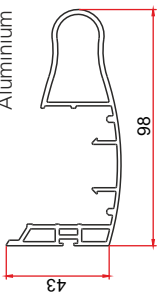
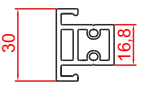
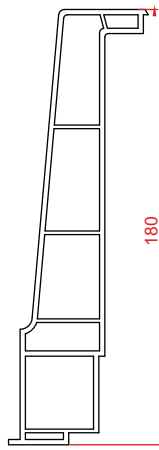
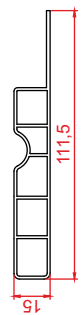
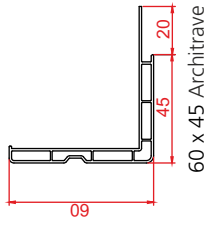
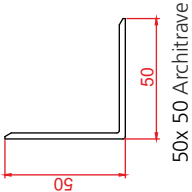
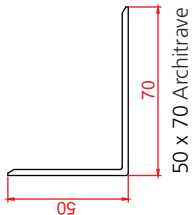
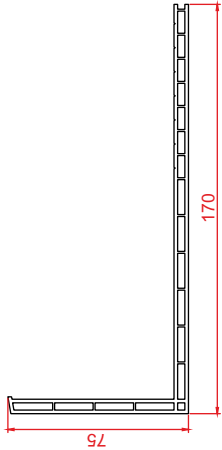
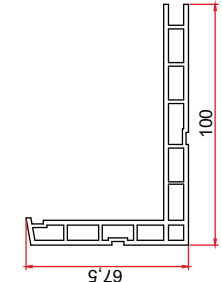
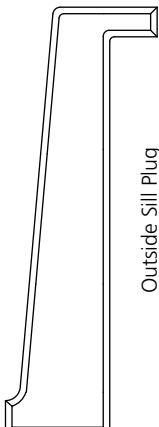
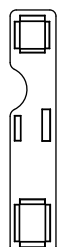
Detail Profiles

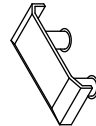
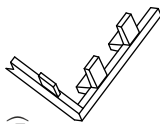
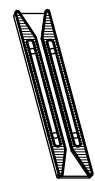
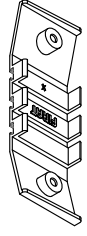
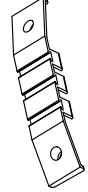
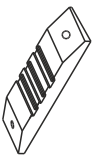
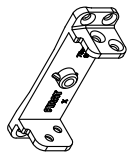
 <p>Lambri 100 19</p>	 <p>24x100 Lambri 100 23.5</p>	 <p>60x90 Architrave 100 90 60</p>	 <p>65x100 Window Architrave 100 65</p>	 <p>Wide Asymmetrical T Profile 43.5 23.5</p>	 <p>Narrow Asymmetrical T Profile 31 23.5</p>	 <p>Corner Piece 15 20</p>	 <p>T Profile 15.2 32</p>	 <p>Lining Adapting Profile 28</p>	 <p>Closing Profile 37.5 60</p>	 <p>Fly Screen Frame 39.6 35.5</p>	 <p>Fly Screen Sash 50 24</p>	 <p>Big Fly Screen Sash 60 34</p>	 <p>Wide Asymmetrical T Profile 43.5 23.5</p>	 <p>Wide Asymmetrical T Profile 31 23.5</p>				
 <p>60 x 90 Griyaj 100 60 28.8 92</p>	 <p>Midi Griyaj 24 6 40</p>	 <p>Pane Separating Profile 24 6</p>	 <p>Coupling Profile 12 10</p>	 <p>Aluminium Rail 12 20</p>	 <p>Alu. Sash Adapting Profile 14.8 48</p>	 <p>70 Sliding Aluminium Door Sash Closing 54</p>	 <p>70 Sliding Aluminium Pullable Door Sash Closing 93.7</p>	 <p>70 Sliding Aluminium Corner Profile 46.85 46.85</p>	 <p>70 Sliding Aluminium Threshold 21.3 70</p>	 <p>75 Sliding Aluminium Pullable Door Sash Closing 42 98</p>	 <p>Flyscreen Mullion Profile 30 16.8</p>	 <p>Outside Sill Profile 180</p>	 <p>Indoor Sill Profile 111.5 5</p>	 <p>60 x 90 Architrave 60 45 20</p>	 <p>50 x 50 Architrave 50 50</p>	 <p>50 x 70 Architrave 50 70</p>	 <p>Lining Profile 170 X 75 170 75</p>	 <p>Lining Profile 100 X 67,5 100 67,5</p>
 <p>Outside Sill Plug</p>	 <p>Indoor Sill Plug</p>	 <p>Mounting Plug</p>	 <p>Windshield</p>	 <p>Linematic</p>	 <p>Buffers For Glass (1,5 mm, 3,5 mm, 5 mm)</p>	 <p>75 Sliding Frame Stopper</p>	 <p>75 Sliding Fix Frame Stopper</p>	 <p>70 Sliding Frame Stopper</p>	 <p>75 Sliding Vertical Mullion Connector</p>									

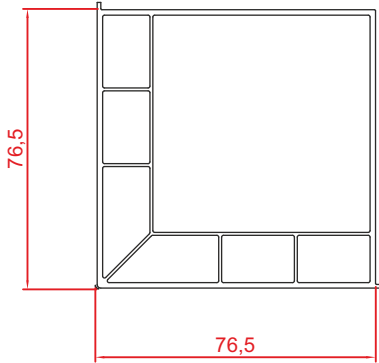

75 Sliding Angled Post Box 90° Profile

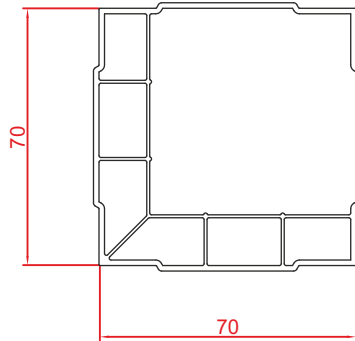

70 Sliding Angled Post Box 90° Profile

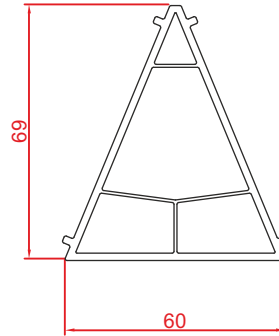

75 Sliding 135° Angled Box Profile

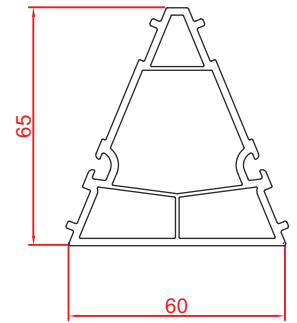

70 Sliding 135° Angled Box Profile

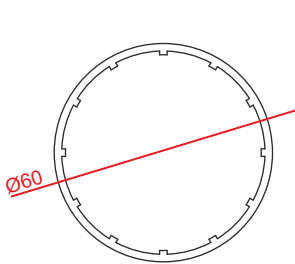

75 Sliding Angled Post Pipe Profile

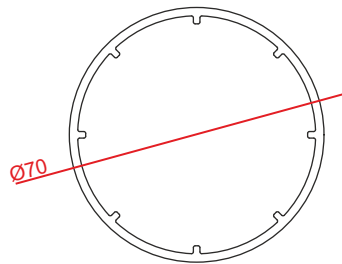

70 Sliding Angled Post Pipe Profile

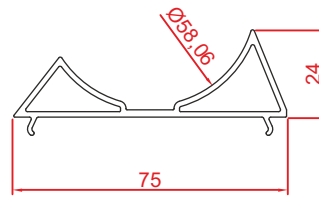

75 Angled Post Adapting Profile

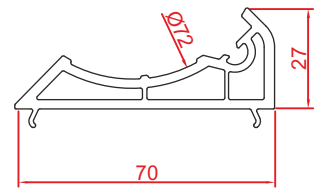

70 Angled Post Adapting Profile

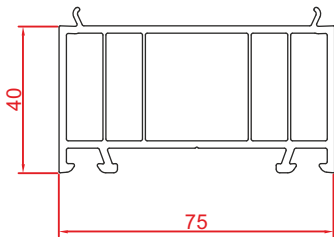

75 Sliding 40 mm Frame Elevator

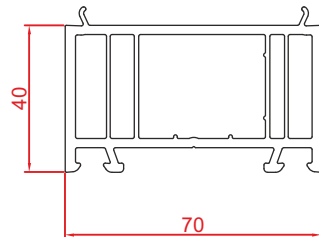

70 Sliding 40 mm Frame Elevator

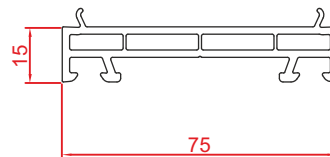

75 Sliding 15 mm Frame Elevator

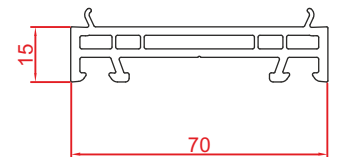

70 Sliding 15 mm Frame Elevator

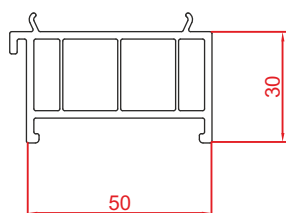

75 Sliding Frame Base Mounting Profile

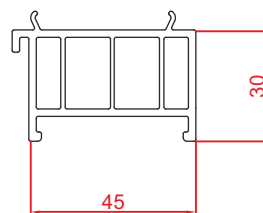

70 Sliding Frame Base Mounting Profile

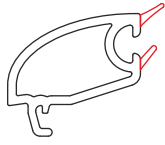

5 mm Glass Bead

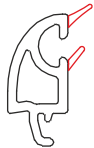
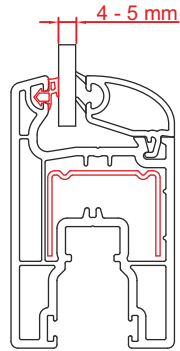

20 mm Glass Bead

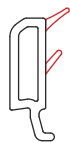
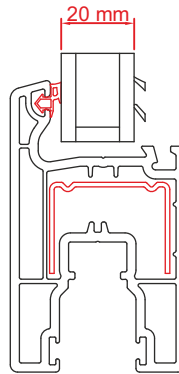

24 mm Glass Bead

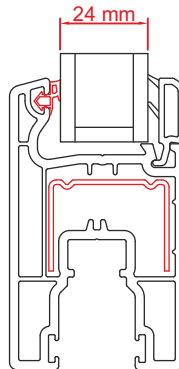

1. Common sash and door sash profiles are used in 75 and 70 mm sliding systems.
2. You only need to use 70 or 75 closing profiles suitable for the frame profile you will use.
3. You must use door sash profile for sizes higher than 1.8 meters.
4. For the door sash applications higher than 2.2 mt, you should use aluminum closing profile.

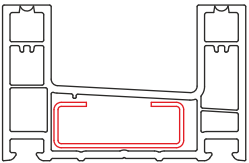
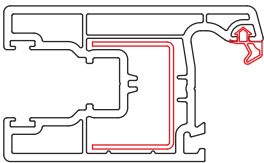
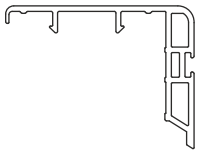
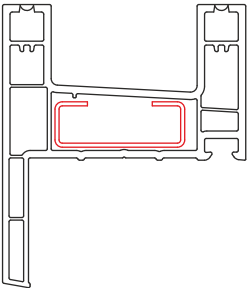
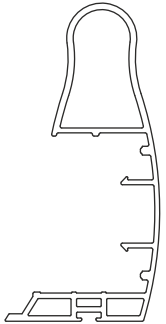
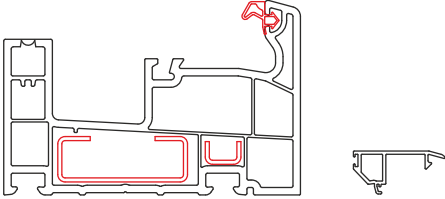
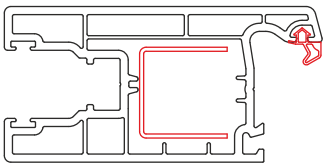
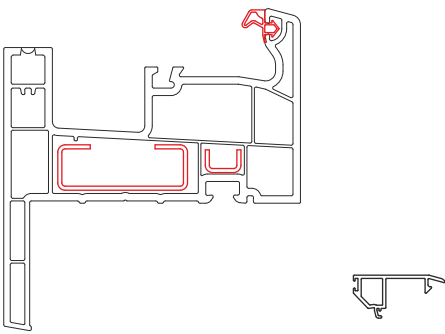
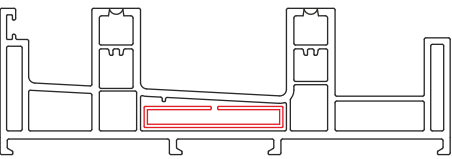
Sliding Frame Profiles	Sash Profiles That Can Be Used	Closing Profiles That Can Be Used
<p>75 Sliding Frame</p> 	<p>Sliding Sash</p> 	<p>75 Sliding Sash Closing</p> 
<p>75 Sliding Frame With Architrave</p> 		<p>75 Sliding Aluminium Sash Closing</p> 
<p>75 Sliding Fix Frame</p> 	<p>Sliding Door Sash</p> 	
<p>75 Sliding Fix Frame With Architrave</p> 	<p>75 Sliding Fix Frame Closing</p> 	

1. Common sash and door sash profiles are used in 75 and 70 mm sliding systems.
2. You only need to use 70 or 75 closing profiles suitable for the frame profile you will use.
3. You must use door sash profile for sizes higher than 1.8 meters.
4. For the door sash applications higher than 2.2 mt, you should use aluminum closing profile.

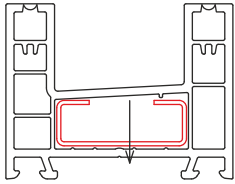
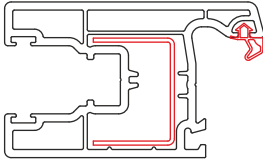
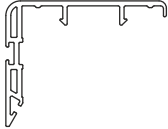
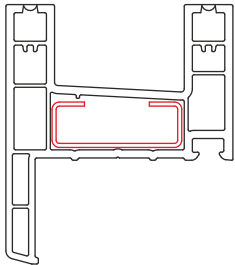
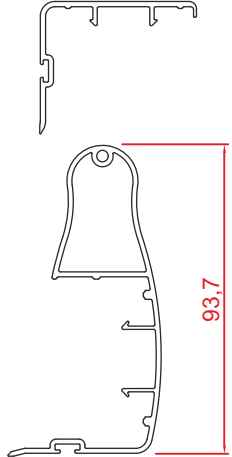
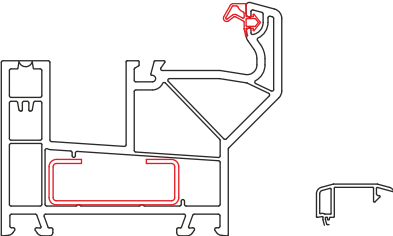
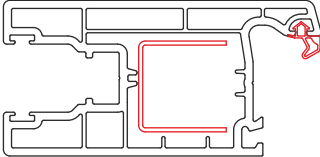
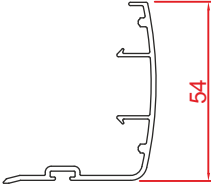
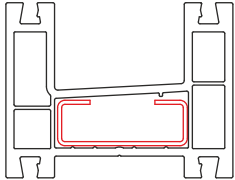
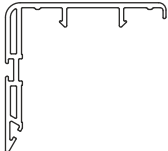
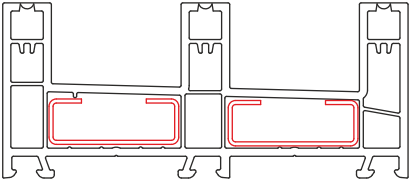
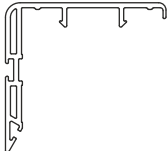
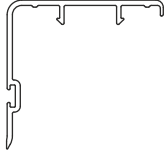
Sliding Frame Profiles	Sash Profiles That Can Be Used	Closing Profiles That Can Be Used
<p>70 Sliding Frame</p> 	<p>Sliding Sash</p> 	<p>70 Sliding Sash Closing With Seal</p> 
<p>70 Sliding Frame With Architrave</p> 		<p>70 Sliding Sash Closing</p> 
<p>70 Sliding Fix Frame</p> 	<p>Sliding Door Sash</p> 	<p>70 Sliding Aluminium Pullable Door Sash Closing</p> 
<p>70 Sliding Fix Frame With Architrave</p> 		<p>70 Sürme Alm. Kanat Kapama</p> 
<p>Sliding Three Track Frame</p> 		<p>70 Sliding Aluminium Door Sash Closing Profile</p>  <p>70 Sliding Door Sash Closing</p> 

1. Common sash and door sash profiles are used in 75 and 70 mm sliding systems.
2. You only need to use 70 or 75 closing profiles suitable for the frame profile you will use.
3. You must use door sash profile for sizes higher than 1.8 meters.
4. For the door sash applications higher than 2.2 mt, you should use aluminum closing profile.

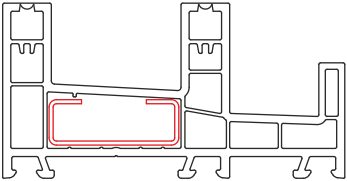
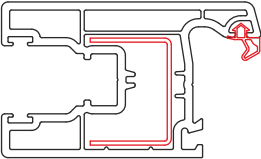
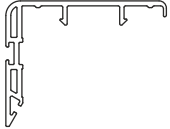
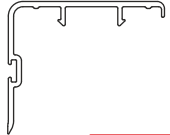
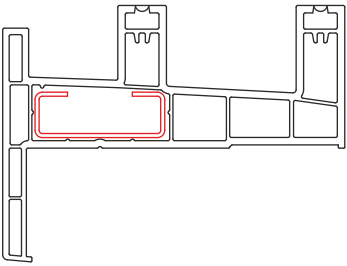
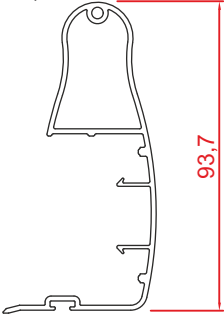
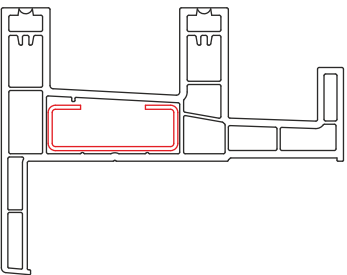
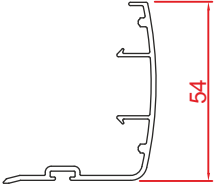
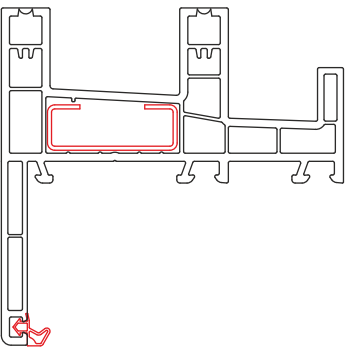
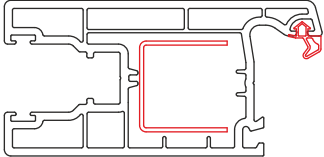
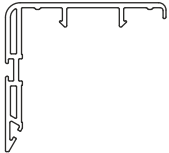
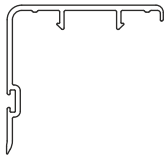
Sliding Frame Profiles	Sash Profiles That Can Be Used	Closing Profiles That Can Be Used
<p>Sliding Frame With Fly Screen</p> 	<p>Sliding Sash</p> 	<p>70 Sliding Sash Closing With Seal</p>  <p>70 Sliding Sash Closing</p> 
<p>Sliding Frame With Inside Fly Screen & Architrave</p> 		 <p>93,7</p>
<p>Sliding Frame With Inside Fly Screen & Architrave</p> 		<p>70 Sliding Aluminium Pullable Door Sash Closing</p>  <p>54</p> <p>70 Sürme Alm. Kanat Kapama</p>
<p>Sliding Frame With Outside Fly Screen & 50 mm Architrave</p> 	<p>Sliding Door Sash</p> 	<p>70 Sliding Aluminium Door Sash Closing Profile</p>  <p>70 Sliding Door Sash Closing</p> 

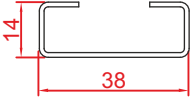
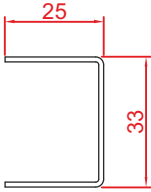
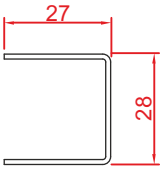
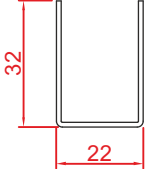
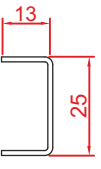
Shape	Usage	Thickness	Inertia Values
	Sliding Frame	1,2 mm	$I_x : 0,28 - I_y : 1,86$
	Sliding Frame With Architrave	1,5 mm	$I_x : 0,33 - I_y : 2,26$
	Sliding Fix Frame		
Sliding Fix Frame with Architrave	2 mm	$I_x : 0,40 - I_y : 2,88$	
Sliding Mullion- Frame			
Sliding Three Track Frame			
Frames with Fly Screen			
	Sliding Sash	1,2 mm	$I_x : 1,76 - I_y : 0,63$
		1,5 mm	$I_x : 2,16 - I_y : 0,77$
		2 mm	$I_x : 2,77 - I_y : 1,00$
	Sliding Door Sash	1,2 mm	$I_x : 1,30 - I_y : 0,73$
	75 Sliding Vertical Mullion	1,5 mm	$I_x : 1,59 - I_y : 0,90$
		2 mm	$I_x : 2,03 - I_y : 1,16$
	Sliding Mullion	1,2 mm	$I_x : 1,07 - I_y : 0,90$
		1,5 mm	$I_x : 1,32 - I_y : 1,09$
		2 mm	$I_x : 1,71 - I_y : 1,37$
	Sliding Fix Profiles	1,2 mm	$I_x : 0,54 - I_y : 0,1$
		1,5 mm	$I_x : 1,0,65 - I_y : 0,11$
		2 mm	$I_x : 0,82 - I_y : 0,14$

Coupling Profile Applications

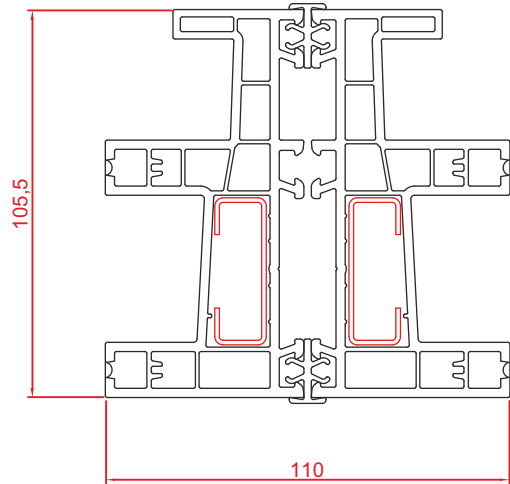
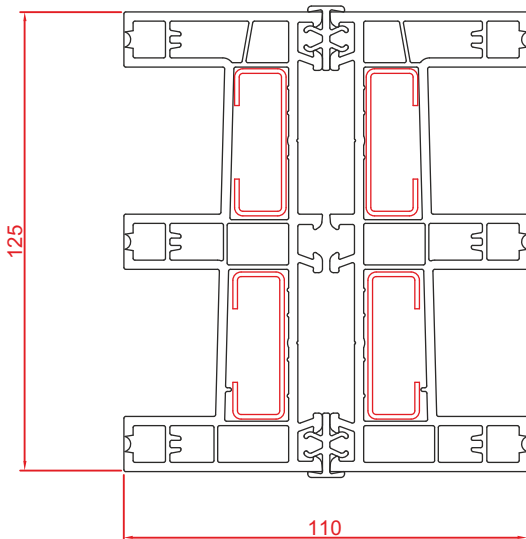
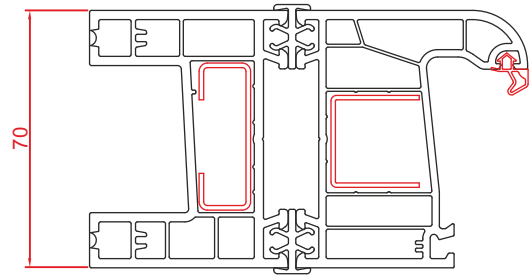
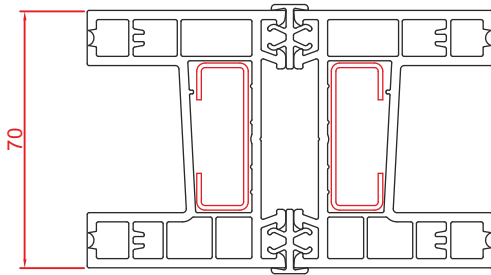
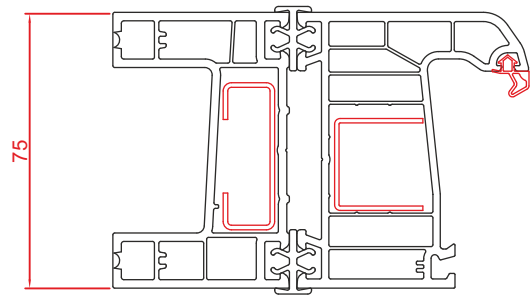
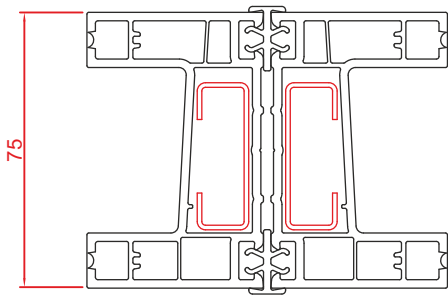
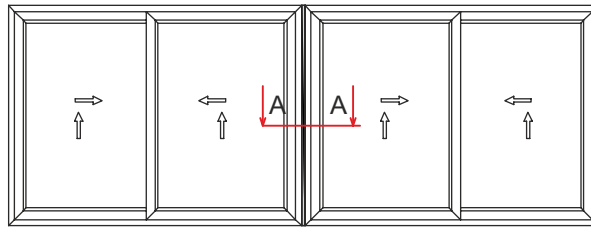

Griyaj Applications

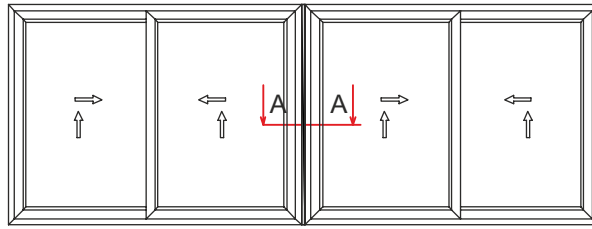

60x100 Griyaj Applications

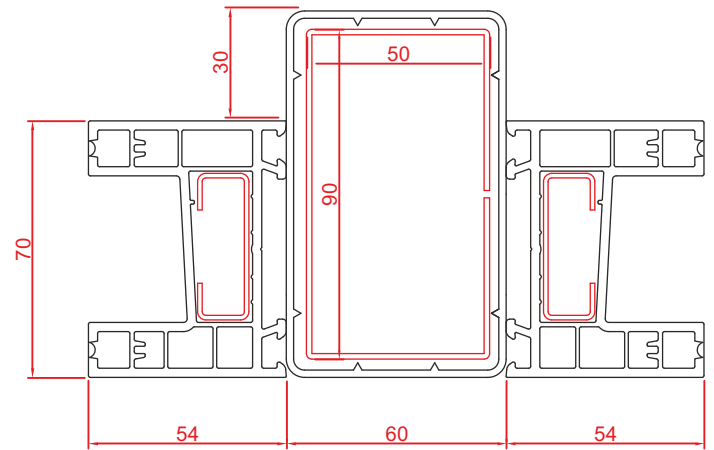
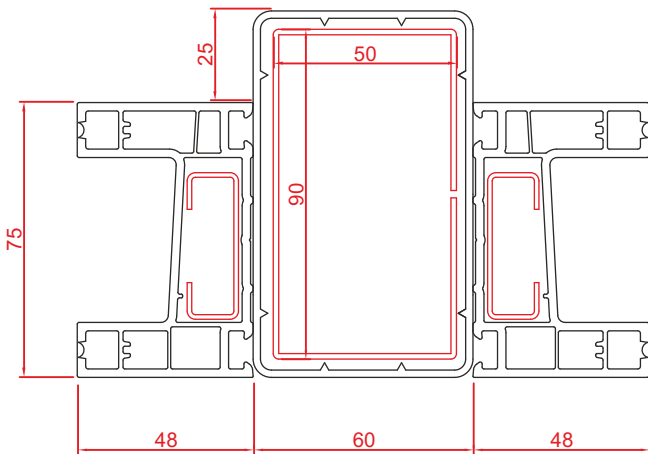

Midi Griyaj Applications

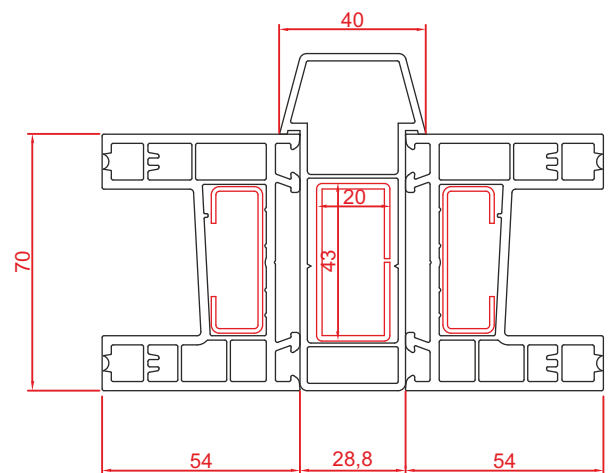
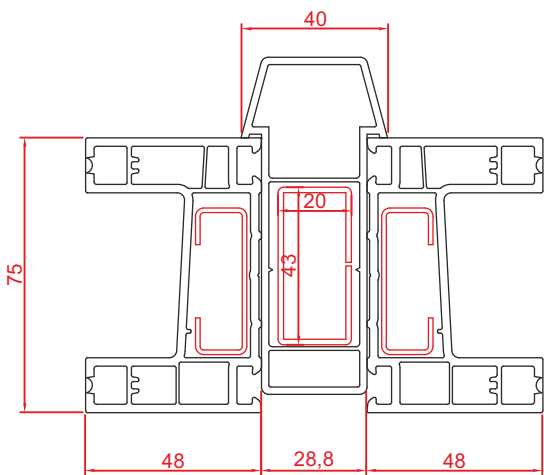

Angled Post Box Applications

Angled Post 90° Box Profile Application

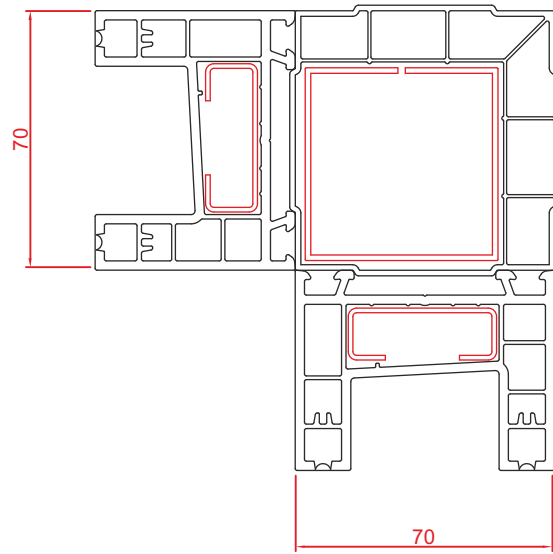
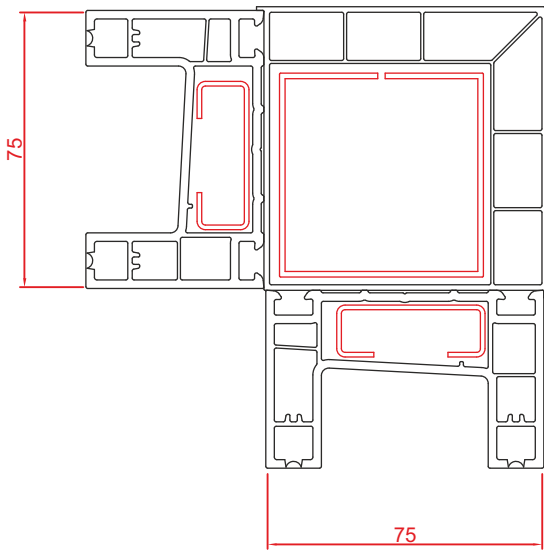
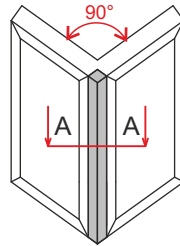

Angled Post 135° Box Profile Application

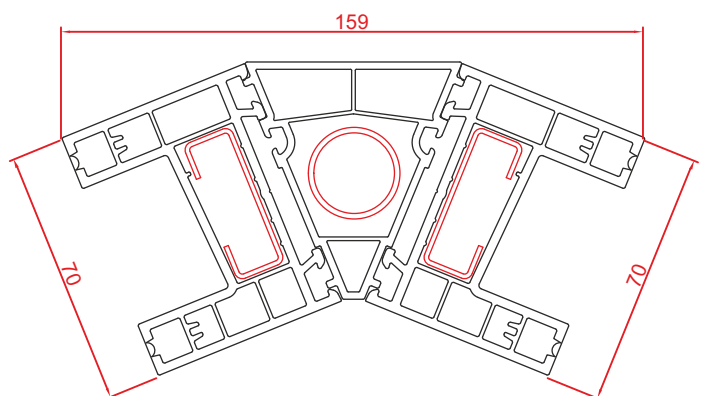
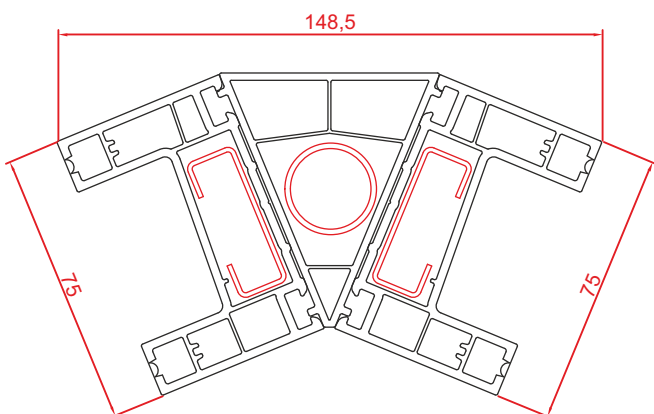
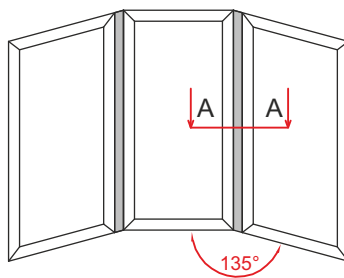

Angled Post Pipe And Adapting Profile Application

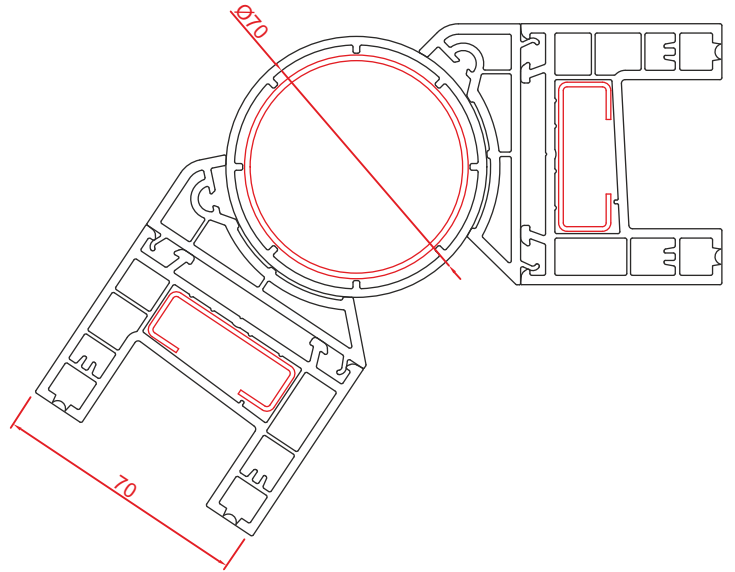
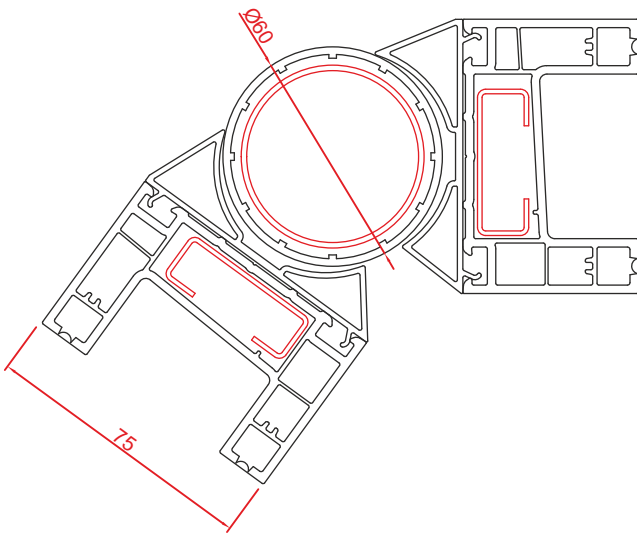
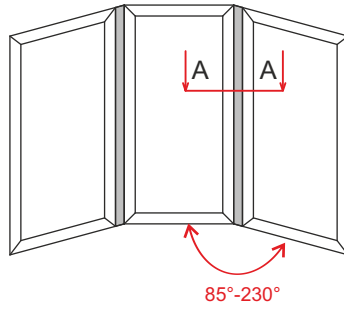

Frame Elevation Application

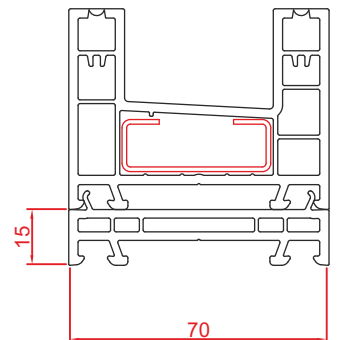
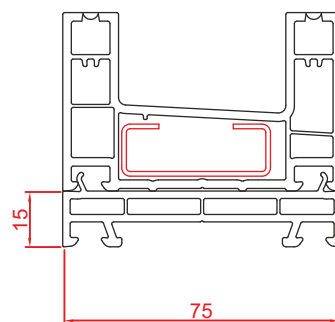
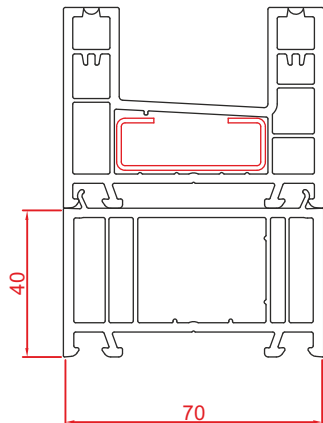
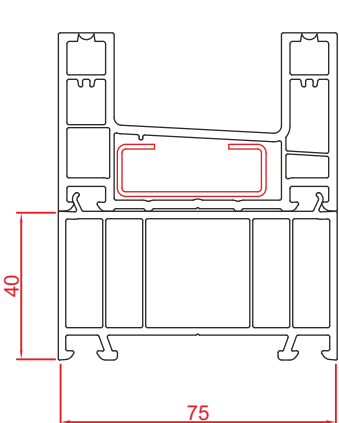
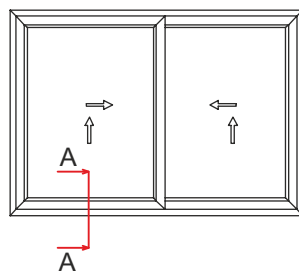

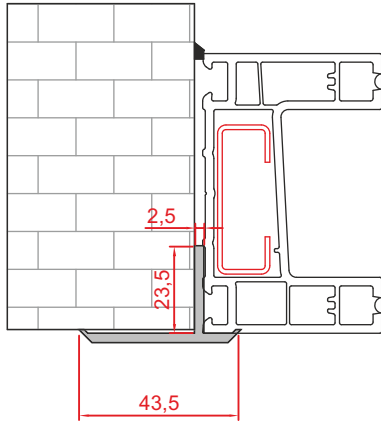

Wide Assymmetric T Application

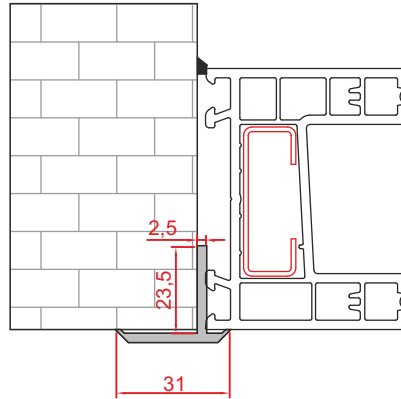

Narrow Assymmetric T Application

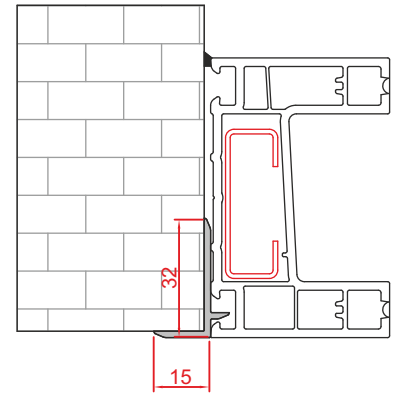

T Profile Application

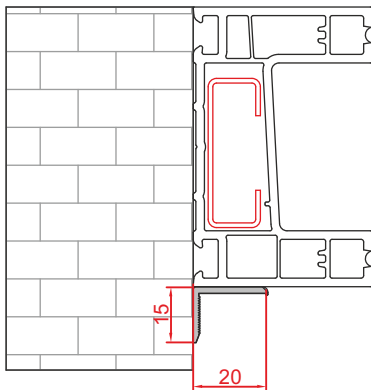

Cornerpiece Application

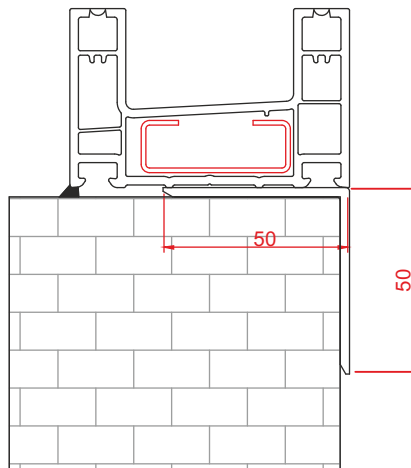

50x50 Lining Application

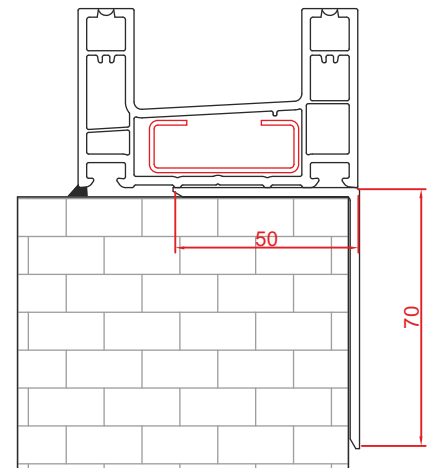

50x70 Lining Application

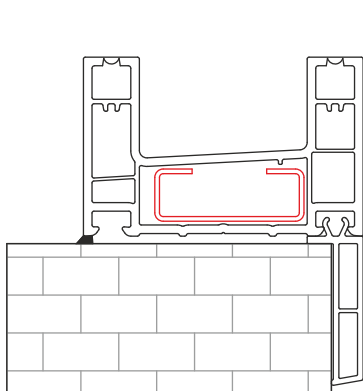

Zero Based Lining Application

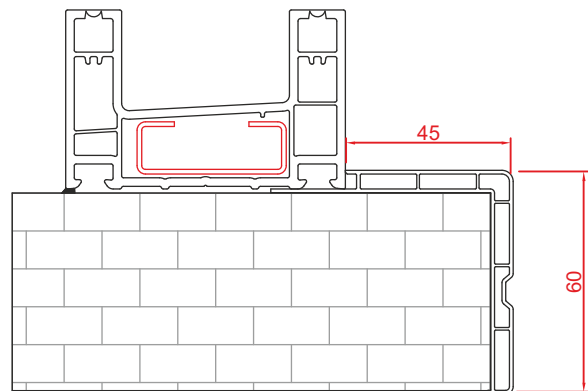

60x45 Lining Application

60 x 90 Lining Application

Lining Leaning Profile Application

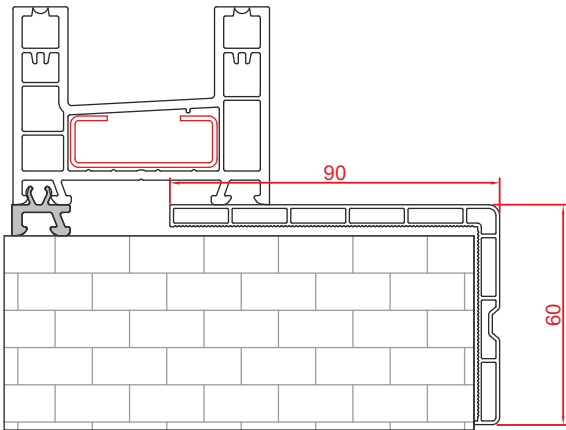

Lining Adapting Profile Application

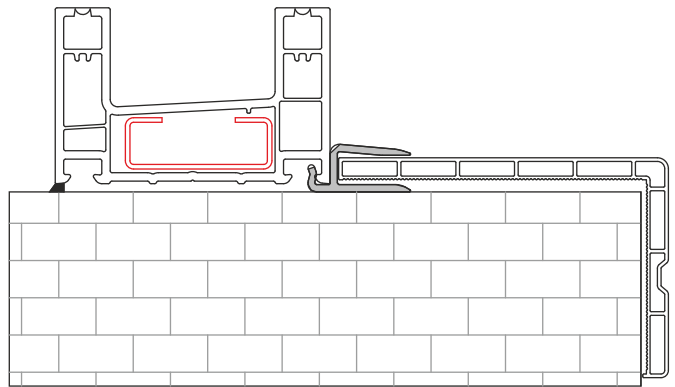

65 x 100 Lining Application

Lining Leaning Profile Application

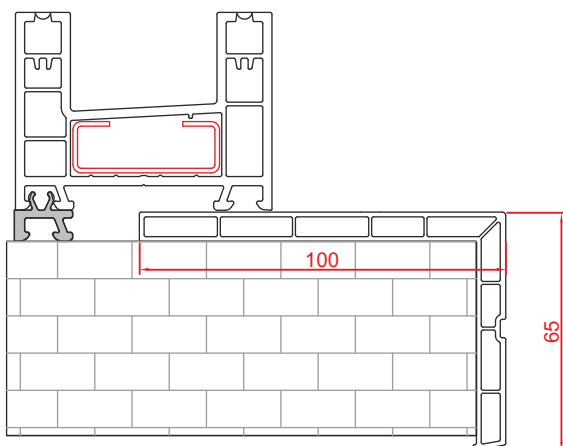

Lining Adapting Profile Application

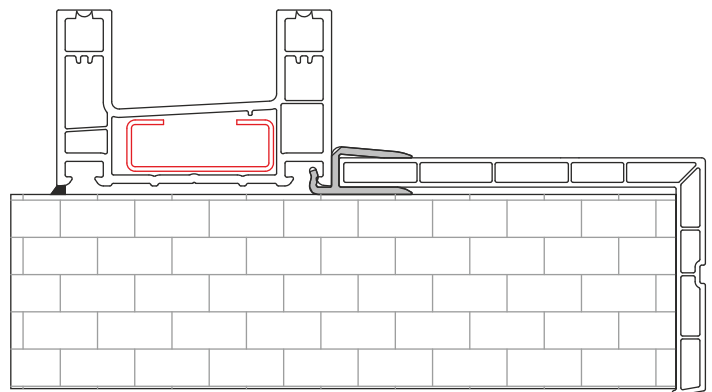

67,5 x 100 mm Lining Application

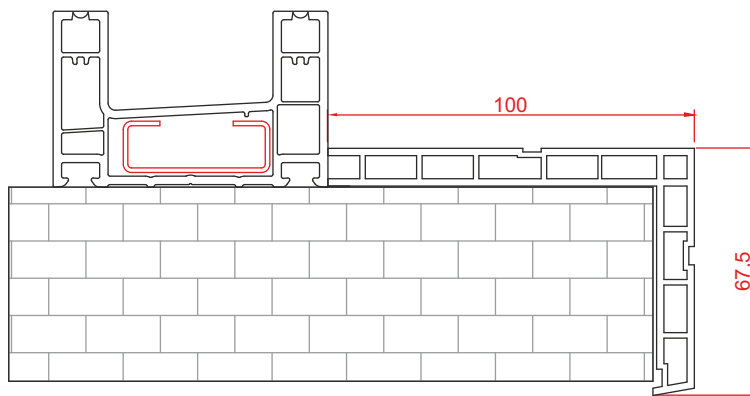

75 x 170 mm Lining Application

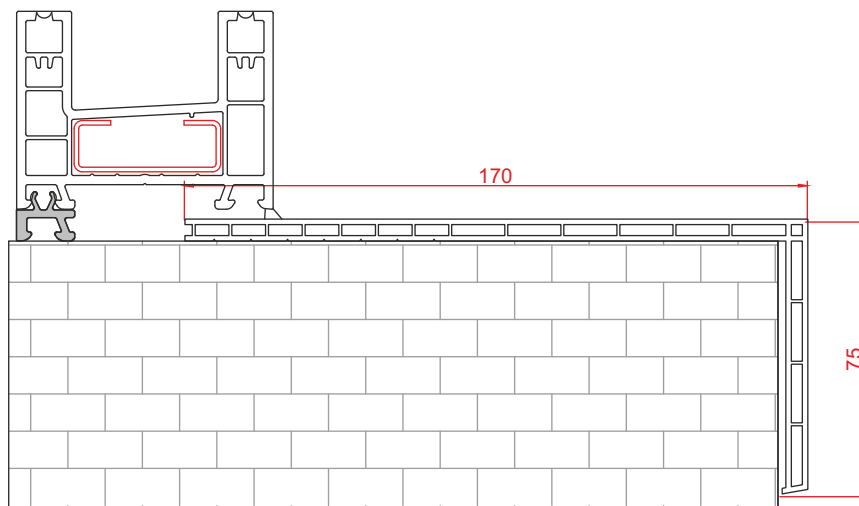

75 Sliding Frame Application

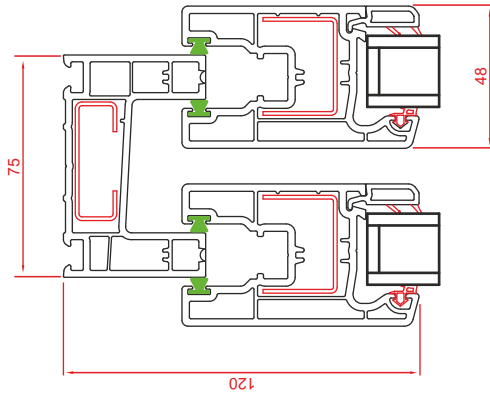

Sash Cutting Measurement	Vertical		Horizontal	
	Measurement (mm)	Pieces	Measurement (mm)	Pieces
	A-74	4	$(B/2)+5$	4

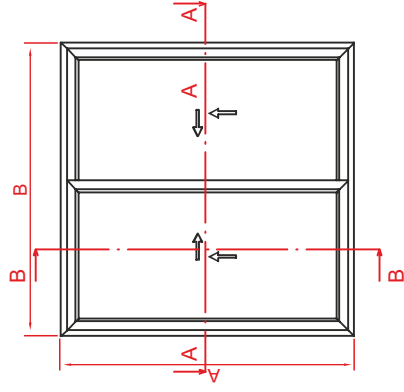

B-B

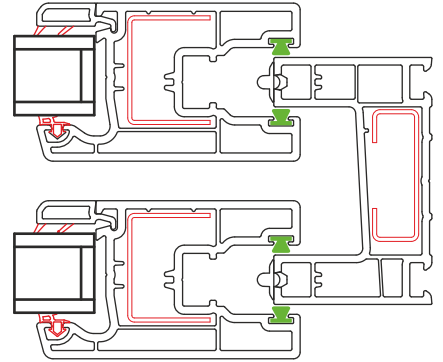

A-A

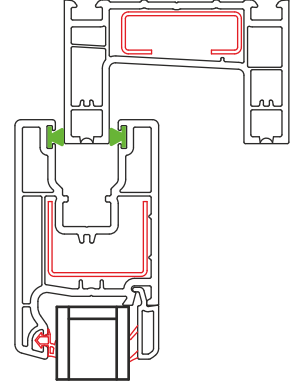
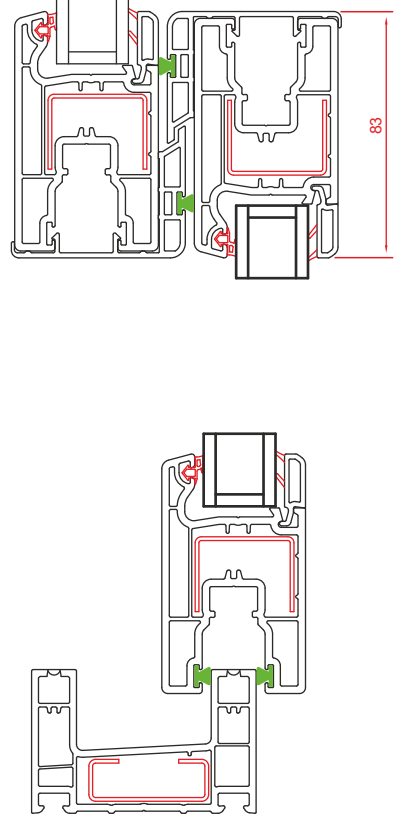

SLIDING SYSTEMS 70-75

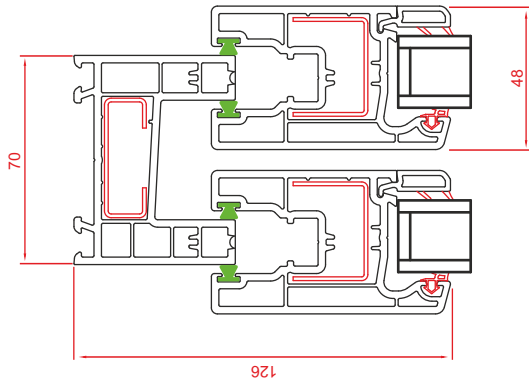

Window Sections

70 Sliding Frame Application

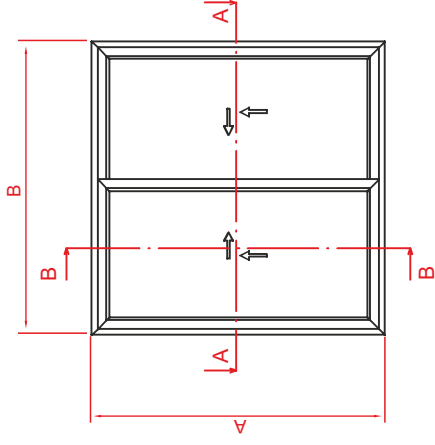

Sash Cutting Measurement	Vertical		Horizontal	
	Measurement (mm)	Pieces	Measurement (mm)	Pieces
	A-86	4	(B/2)	4

B-B

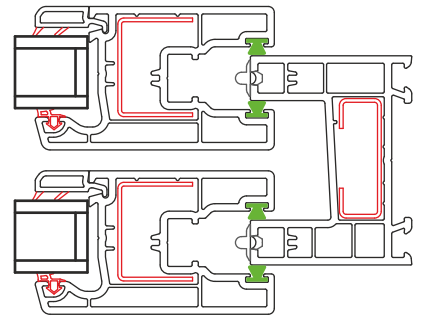

A-A

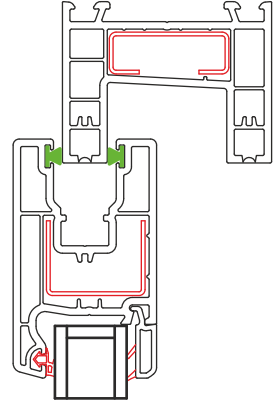
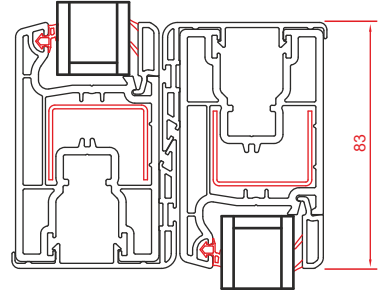

SLIDING SYSTEMS 70-75

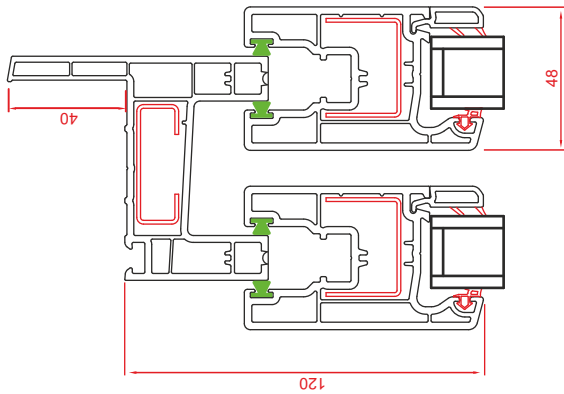

75 Sliding Frame With Architrave Application

Sash Cutting Measurement	Vertical		Horizontal	
	Measurement (mm)	Pieces	Measurement (mm)	Pieces
	A-74	4	$(B/2)+5$	4

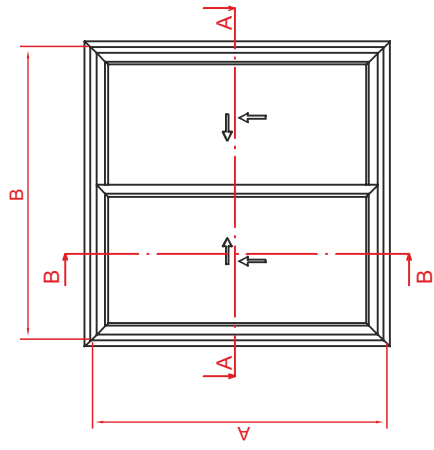

B-B

A and B measurements are external to external measurements of the frame, excluding the architrave.

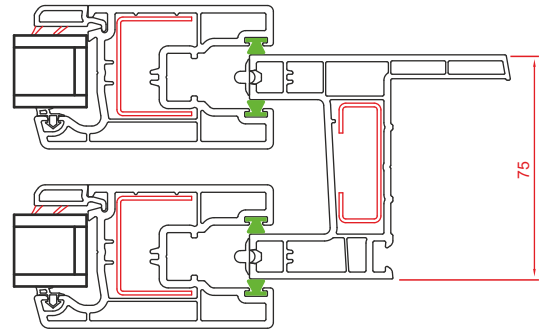

A-A

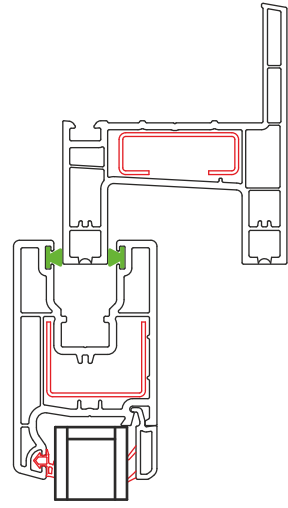
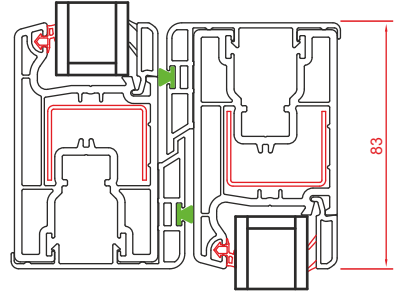

SLIDING SYSTEMS 70-75

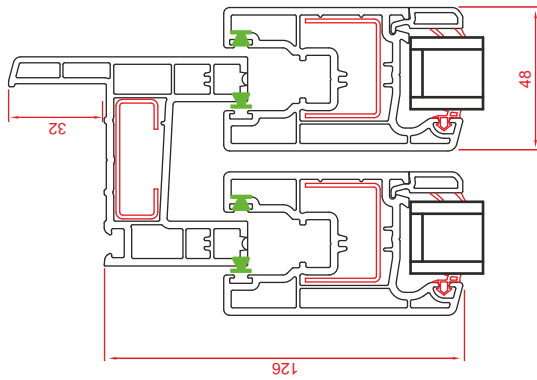

70 Sliding Frame With Architrave Application

Sash Cutting Measurement	Vertical		Horizontal	
	Measurement (mm)	Pieces	Measurement (mm)	Pieces
A-74	A-74	4	$(B/2)+5$	4

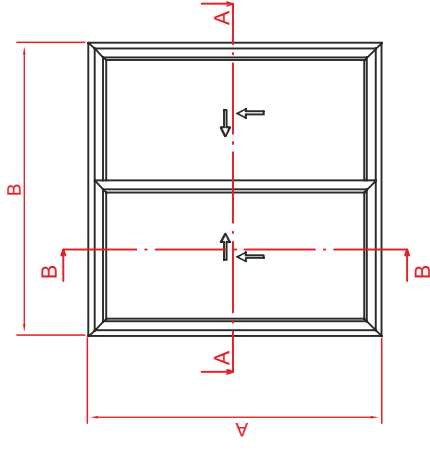

B-B

A and B measurements are external to external measurements of the frame, excluding the architrave.

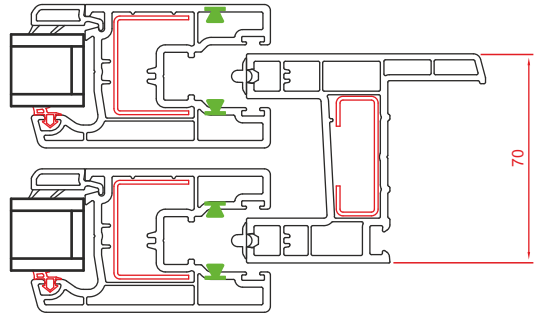

A-A

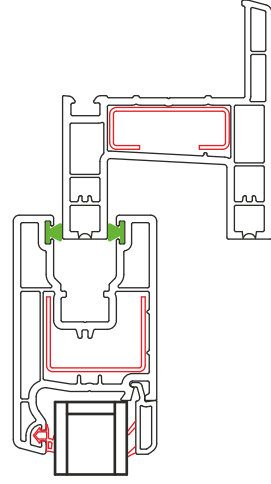
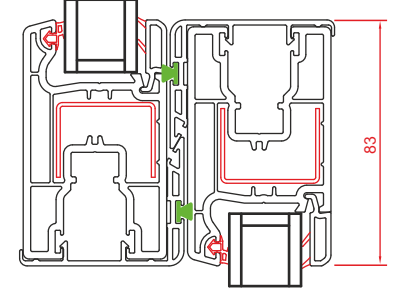
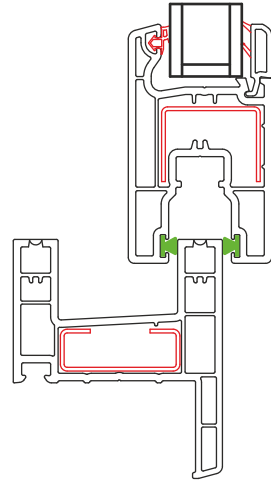

75 Sliding Fix Frame Application

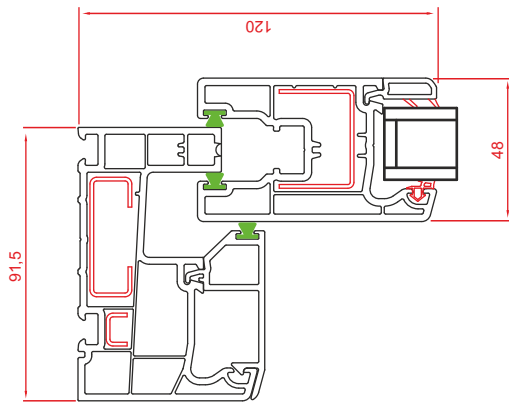

Sash Cutting Measurement	Vertical		Horizontal	
	Measurement (mm)	Pieces	Measurement (mm)	Pieces
	A-74	2	(B/2)+5	2

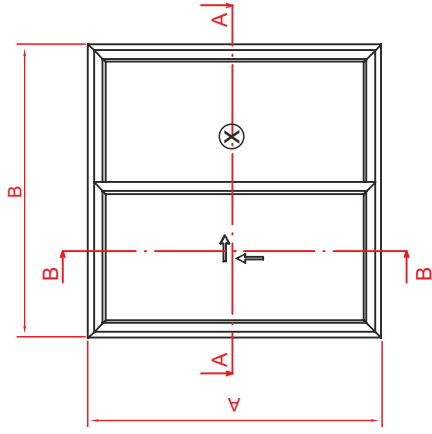
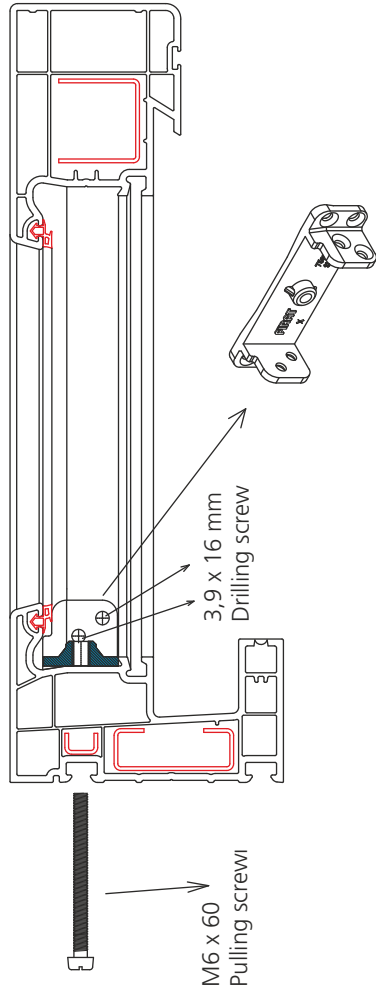

A-A

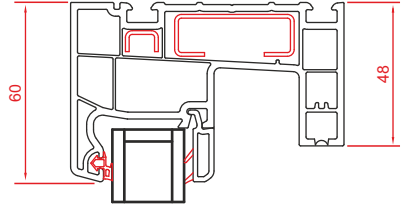
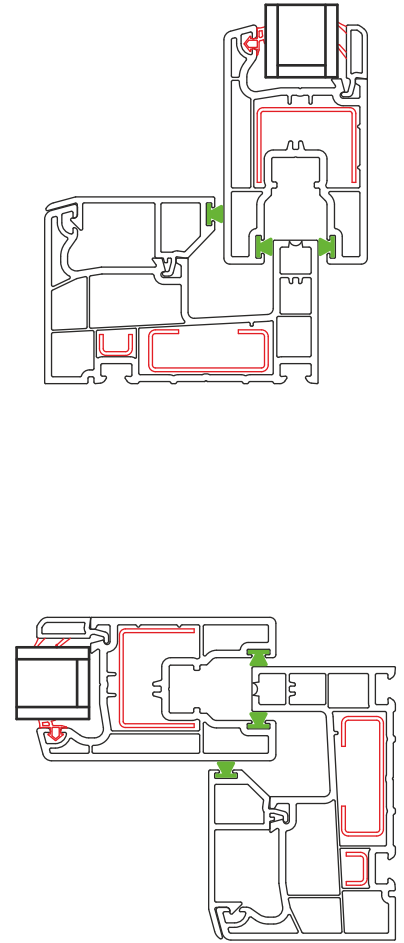

SLIDING SYSTEMS 70-75

Window Sections

70 Sliding Fix Frame Application

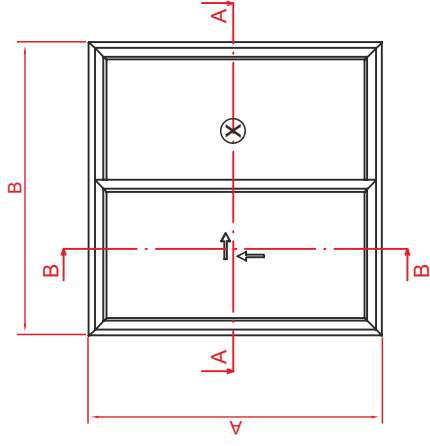
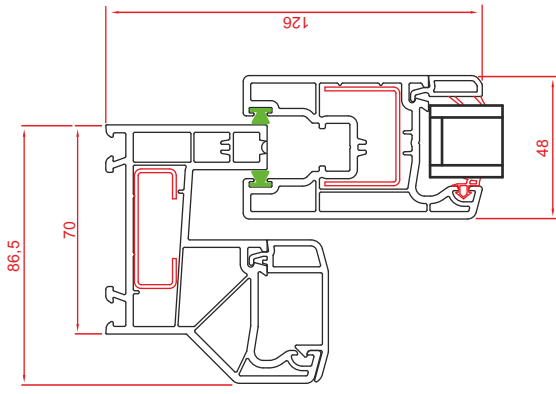

Sash Cutting Measurement	Vertical		Horizontal	
	Measurement (mm)	Pieces	Measurement (mm)	Pieces
A-86	A-86	2	(B/2)	2

B-B

A-A

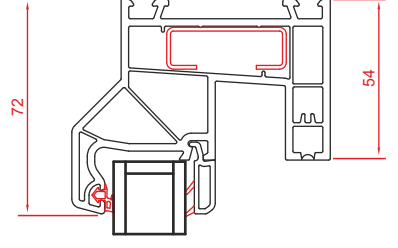
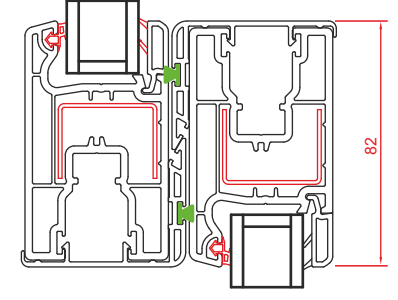
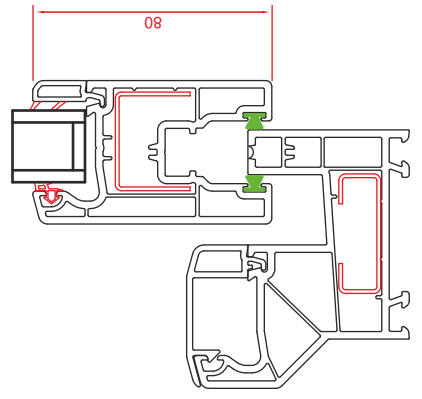

SLIDING SYSTEMS 70-75

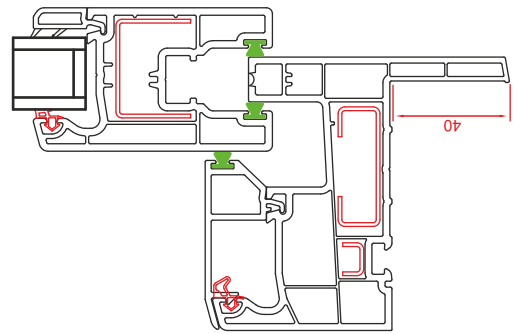
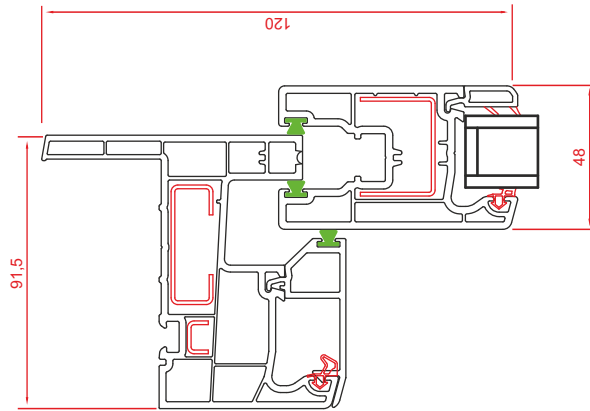

Window Sections

75 Sliding Fix Frame With Architrave Application

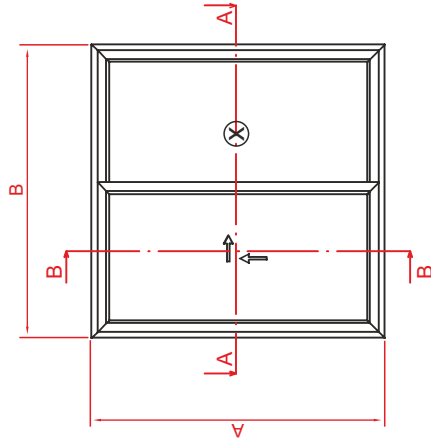

Sash Cutting Measurement	Vertical		Horizontal	
	Measurement (mm)	Pieces	Measurement (mm)	Pieces
	A-74	2	$(B/2)+5$	2

A and B measurements are external to external measurements of the frame, excluding the architrave.

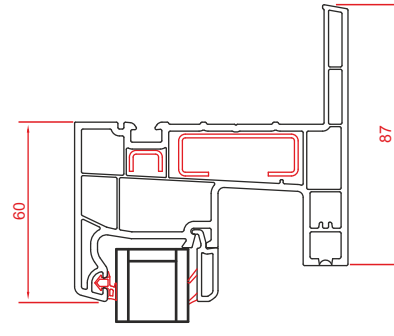
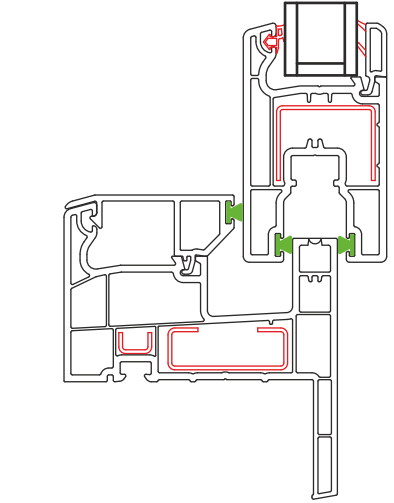
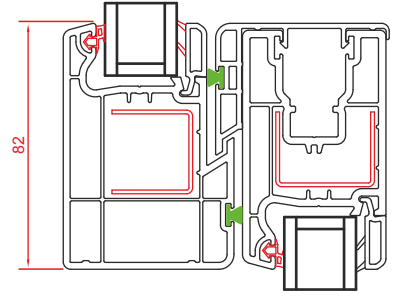

Sliding 75 Three Track Frame

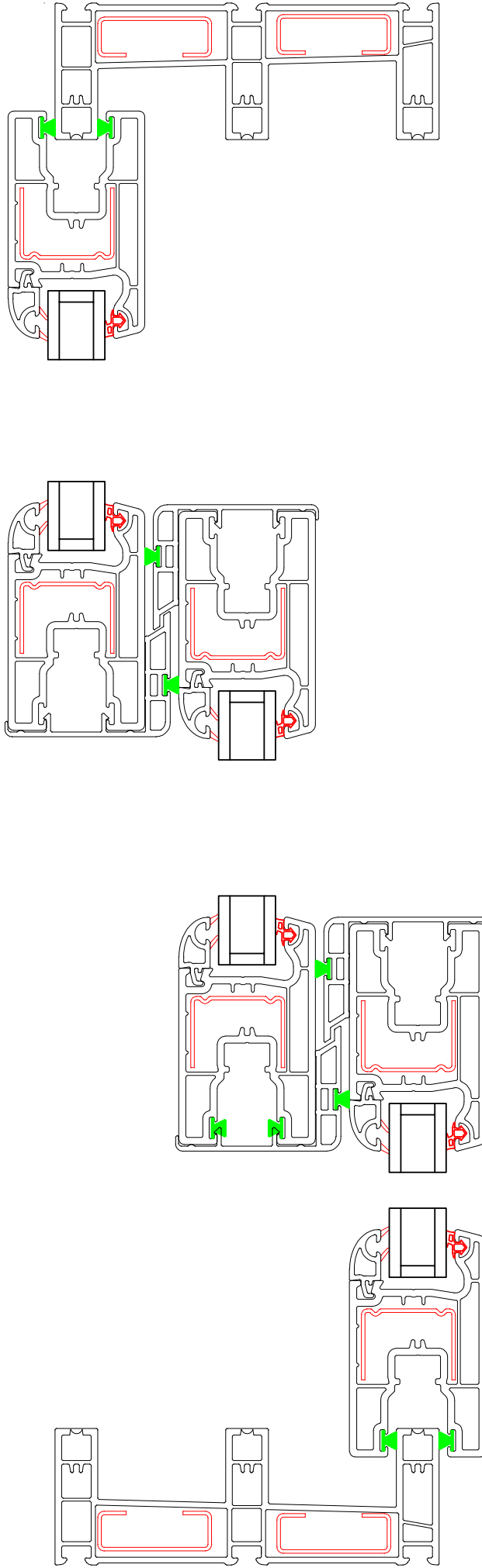

Sliding Three Track Frame Application

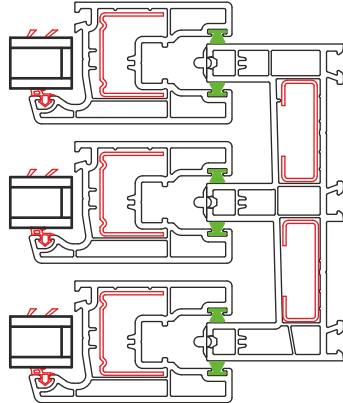
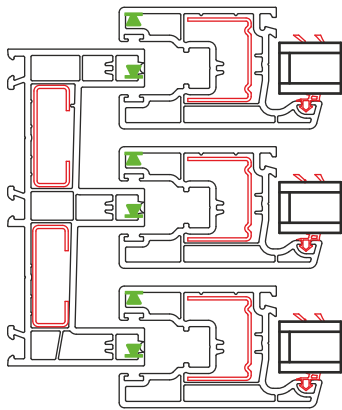

Sash Cutting Measurement	Vertical Measurement (mm)	Pieces	Horizontal Measurement (mm)	Pieces
	A-86	2	$(B/3)+28$	6

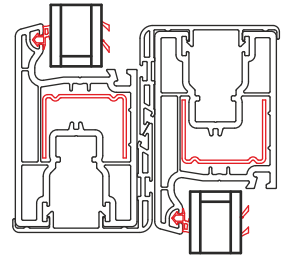
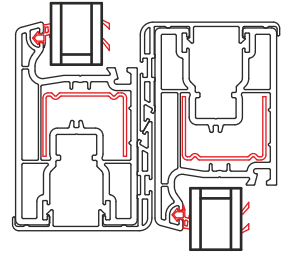
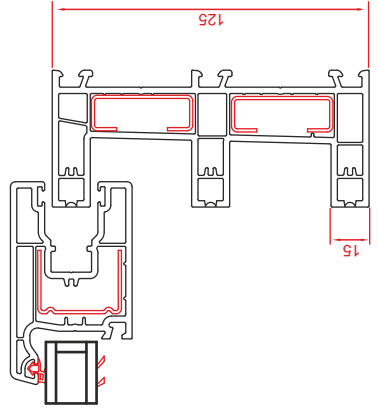
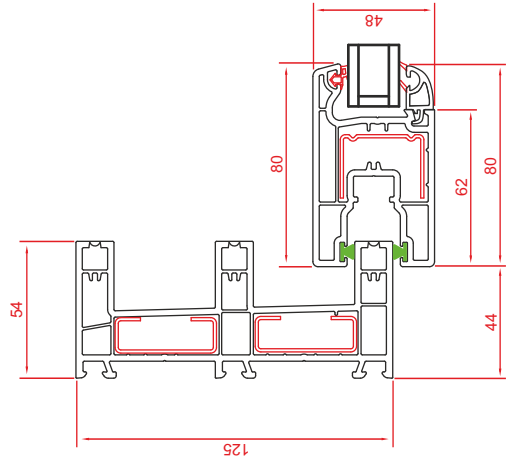
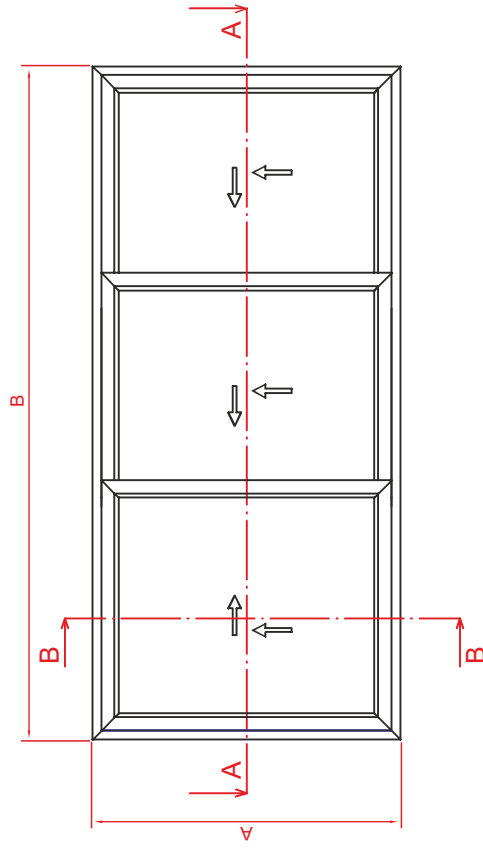

SLIDING SYSTEMS 70-75

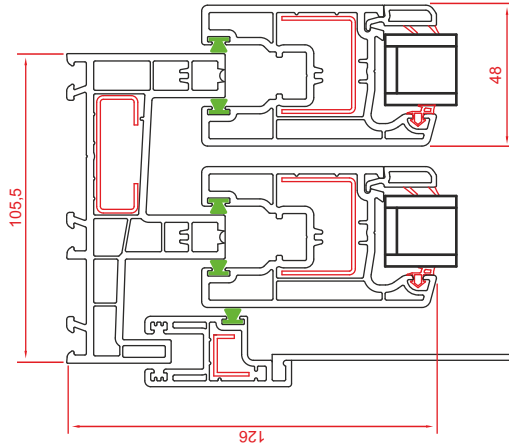

B-B

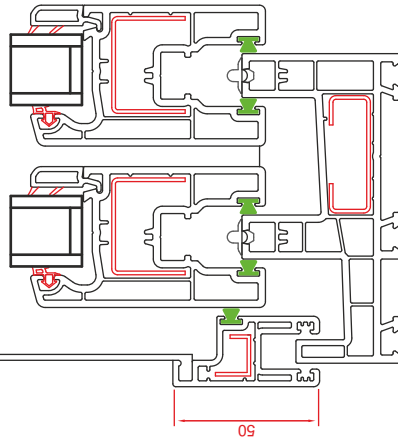

Sliding Frame With Fly Screen Application

Sash Cutting Measurement	Vertical		Horizontal	
	Measurement (mm)	Pieces	Measurement (mm)	Pieces
A-86	A-86	4	B/2	4

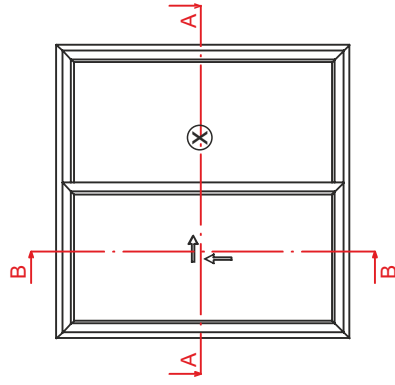

Window Sections

A-A

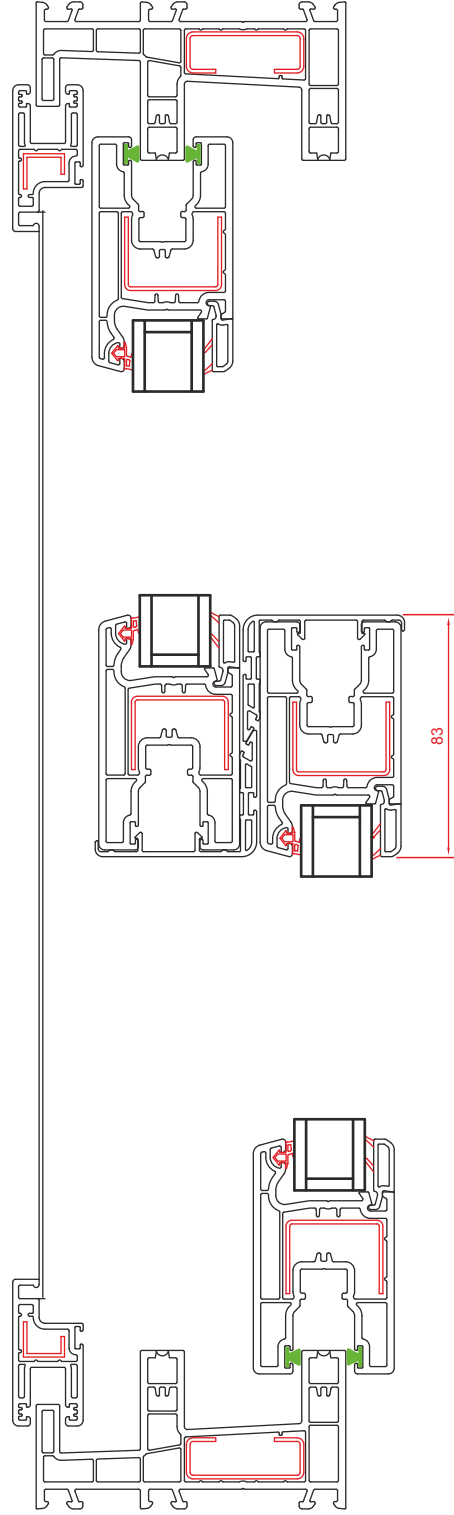

SLIDING SYSTEMS 70-75

Window Sections

Sliding Big Fly Screen Sash And Fly Screen Mullion Application

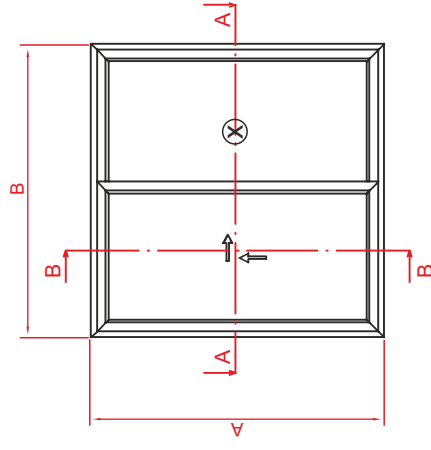
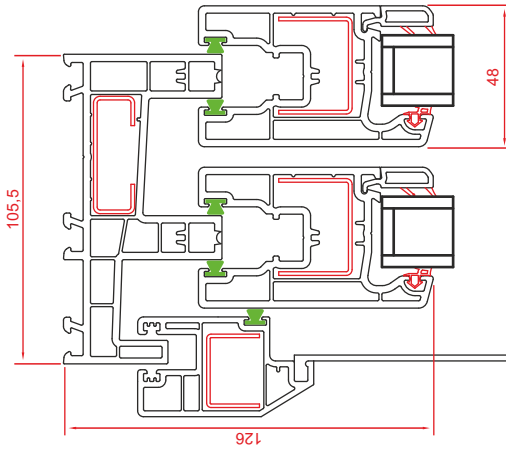

Sash Cutting Measurement	Vertical		Horizontal	
	Measurement (mm)	Pieces	Measurement (mm)	Pieces
	A-86	4	B/2	4

B-B

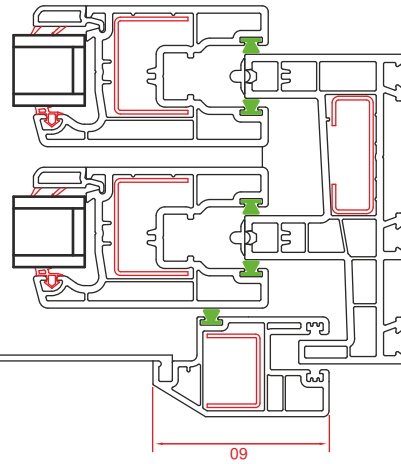

A-A

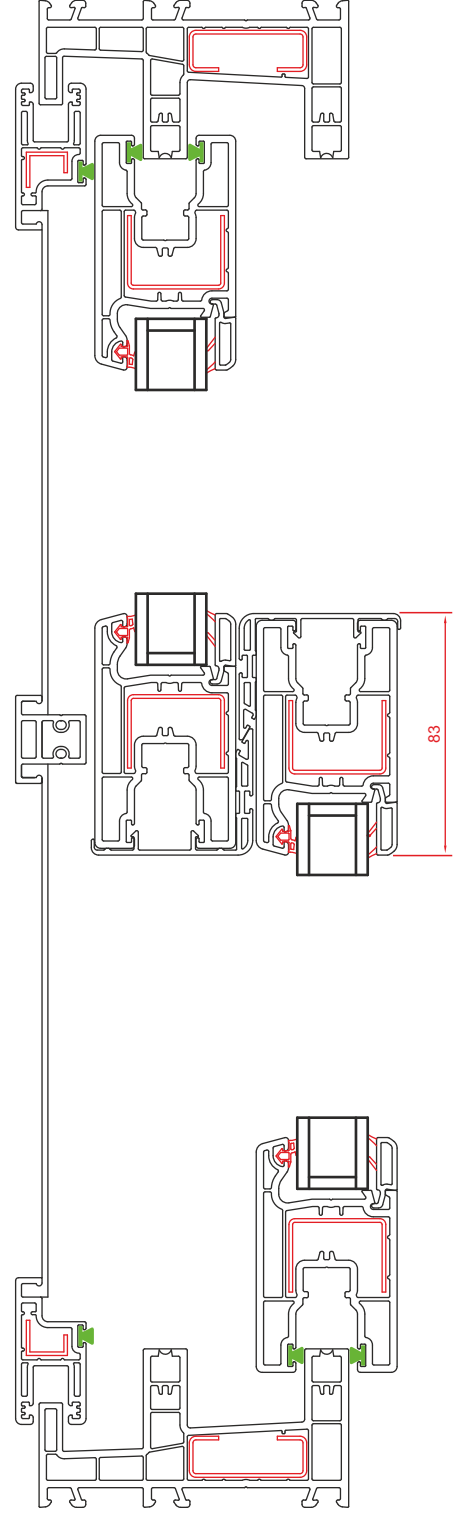

SLIDING SYSTEMS 70-75

Sliding Frame With Inside Fly Screen & Architrave Application

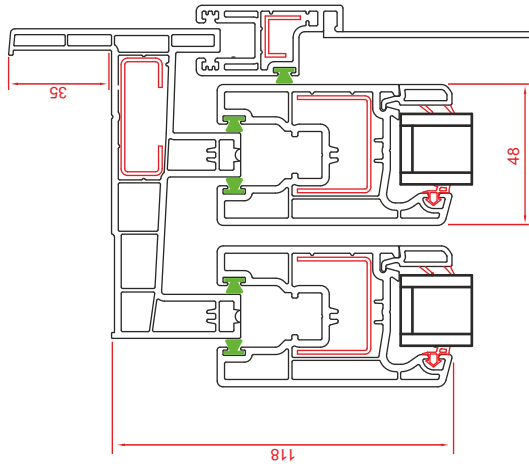

Sash Cutting Measurement	Vertical		Horizontal	
	Measurement (mm)	Pieces	Measurement (mm)	Pieces
A-66	A-66	4	$(B/2)+8$	4

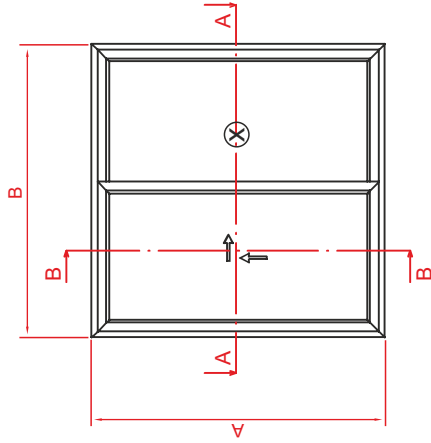

A and B measurements are external to external measurements of the frame, excluding the architrave.

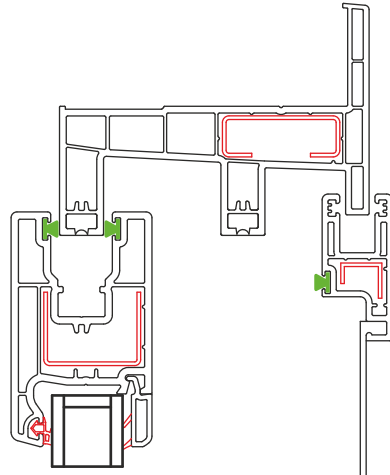
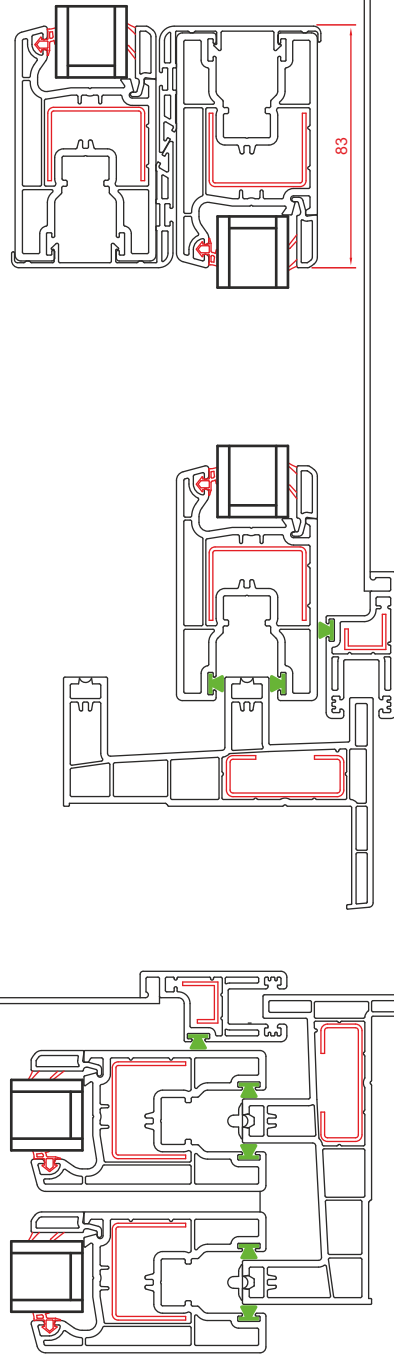

Window Sections

SLIDING SYSTEMS 70-75

Window Sections

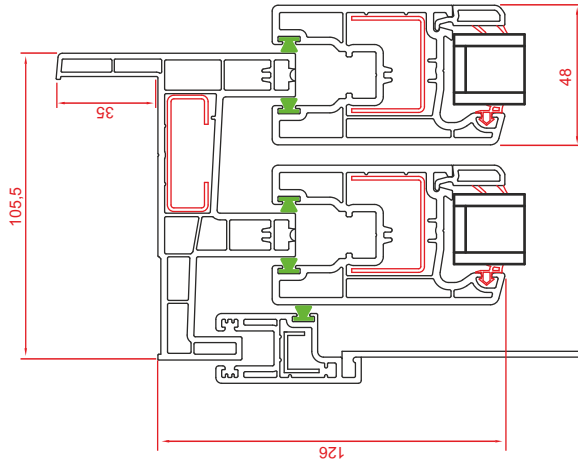

Sliding Frame With Outside Fly Screen & Architrave Application

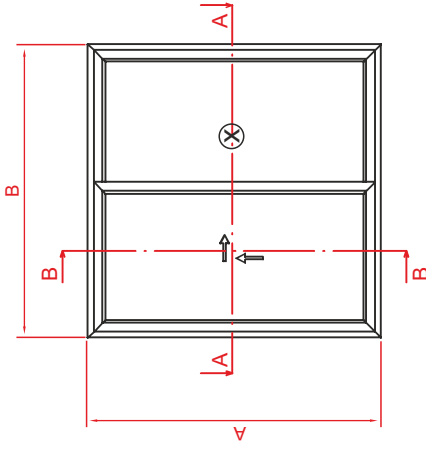

Sash Cutting Measurement	Vertical		Horizontal	
	Measurement (mm)	Pieces	Measurement (mm)	Pieces
A-72	A-72	4	$(B/2)+6$	4

A and B measurements are external to external measurements of the frame, excluding the architrave.

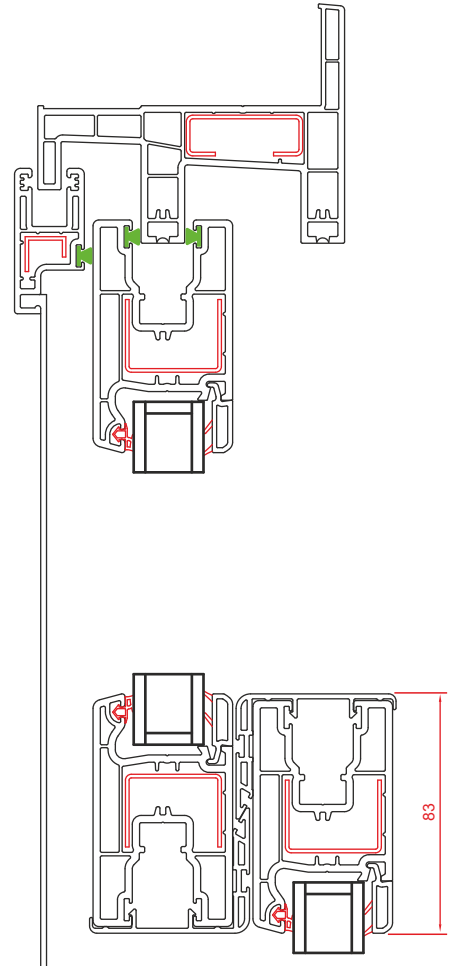
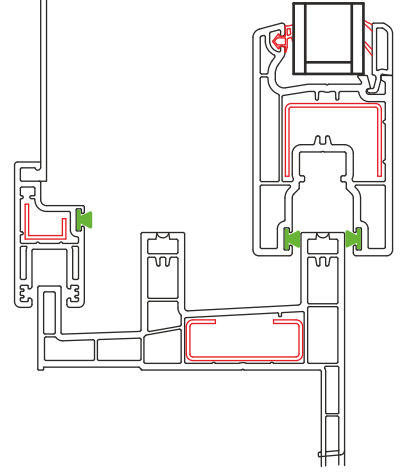
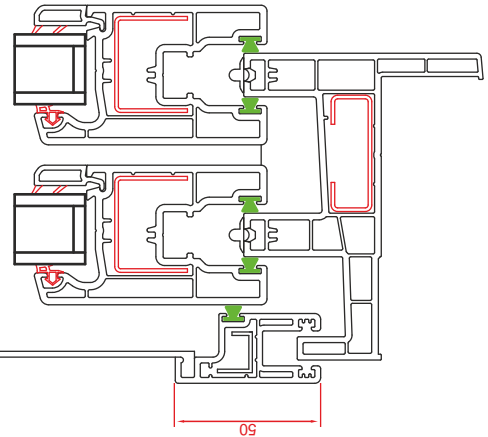

SLIDING SYSTEMS 70-75

Window Sections

Sliding Frame With Outside Fly Screen & 50 mm Architrave Application

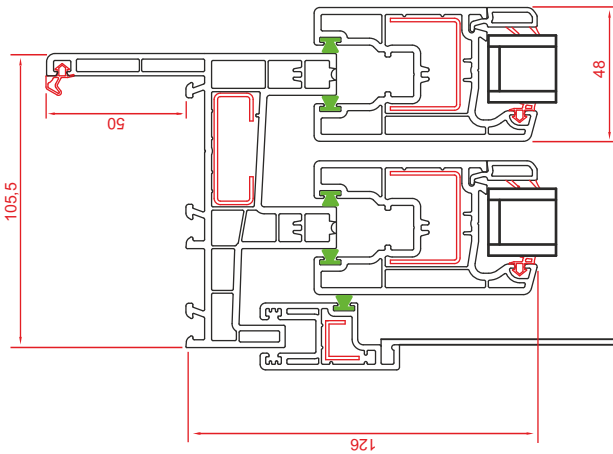

Sash Cutting Measurement	Vertical		Horizontal	
	Measurement (mm)	Pieces	Measurement (mm)	Pieces
A-86	A-86	4	(B/2)	4

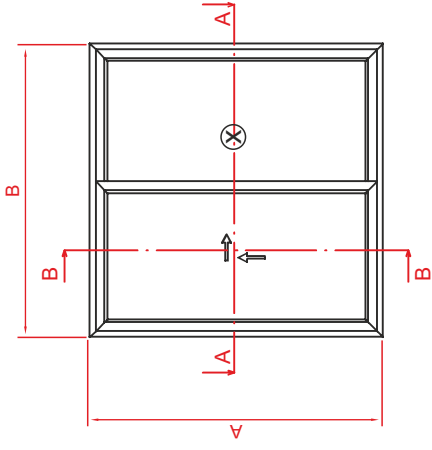

B-B

A and B measurements are external to external measurements of the frame, excluding the architrave.

A-A

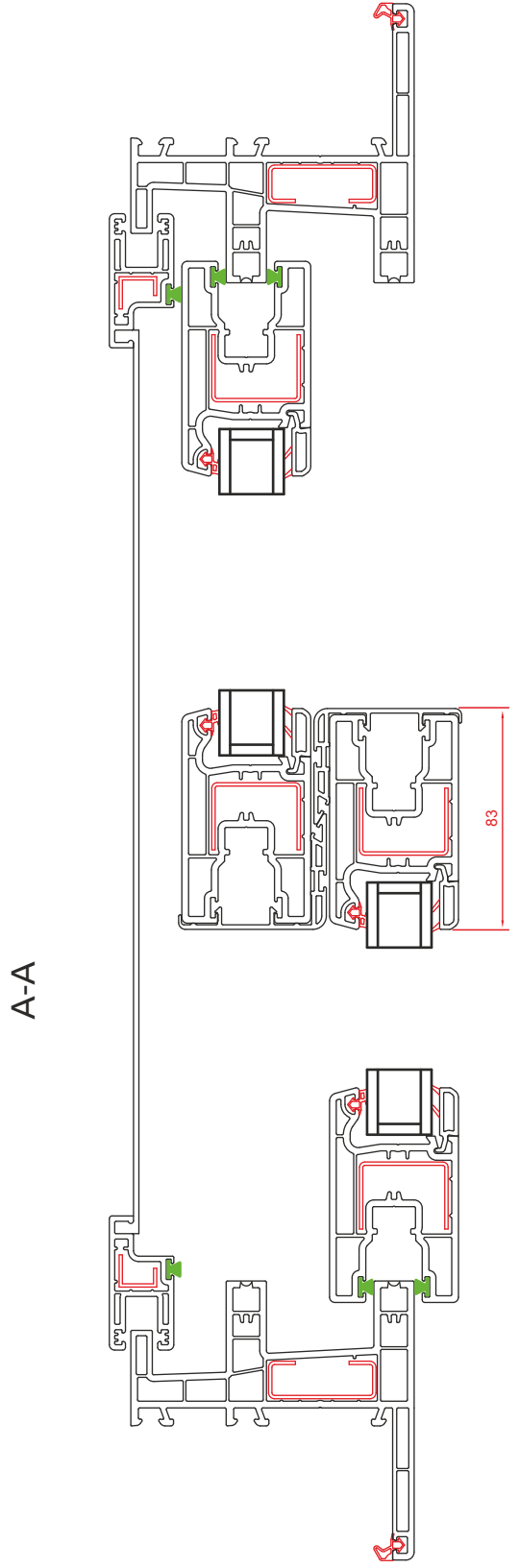

SLIDING SYSTEMS 70-75

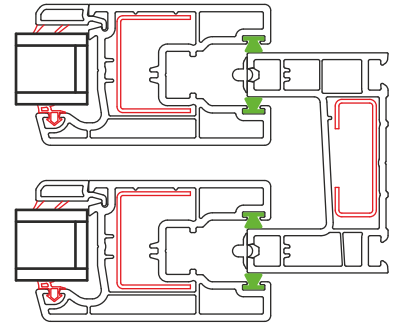
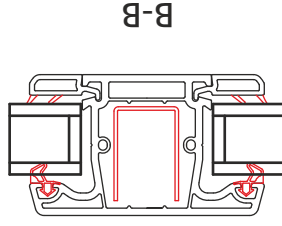
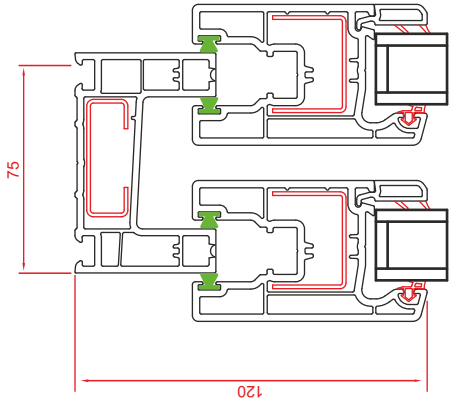

Mullion Profile Application

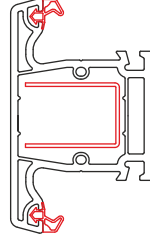
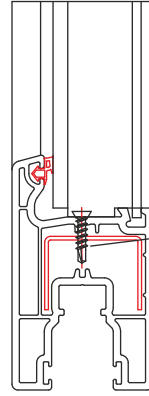
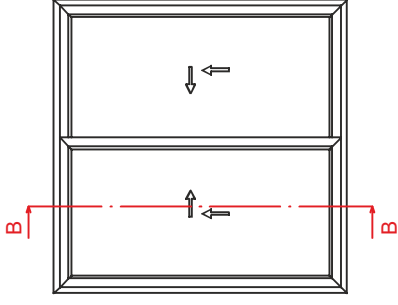

Window Sections

With the screw holes in the mullion profile, it may be combined with the sash without the connector.

SLIDING SYSTEMS 70-75

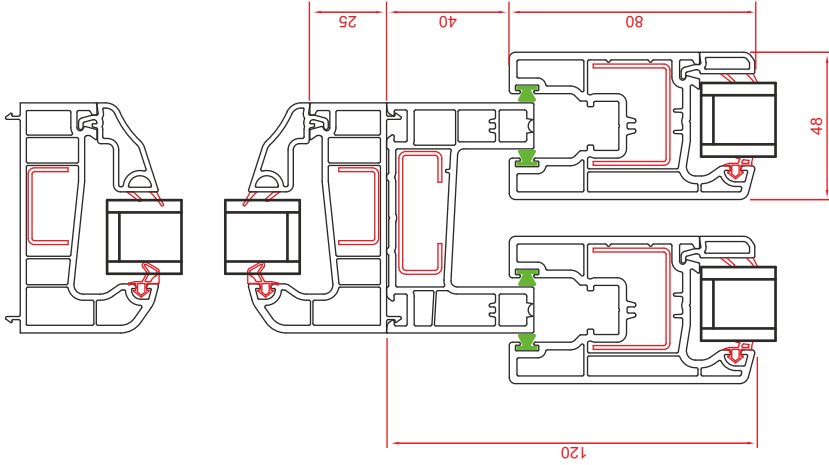

B-B

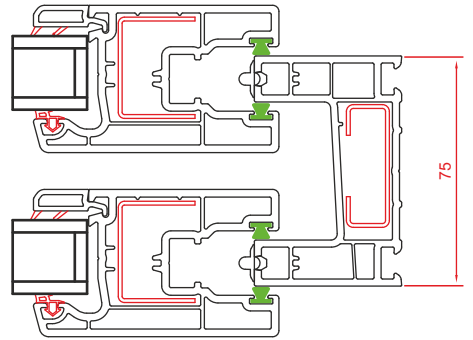

Window Sections

75 Sliding Fix Profile Application

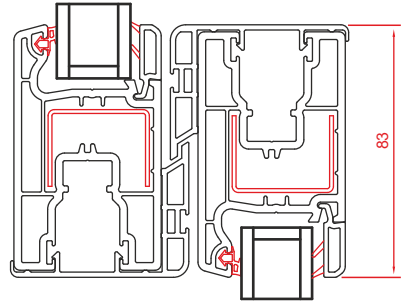
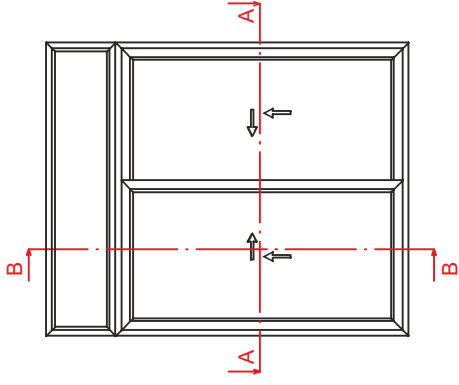

A-A

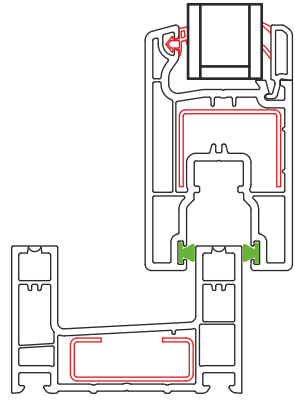

SLIDING SYSTEMS 70-75

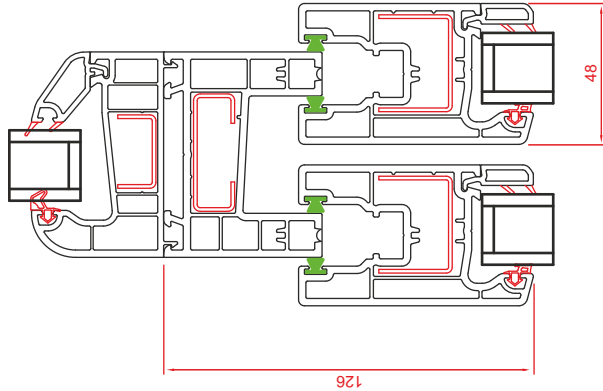
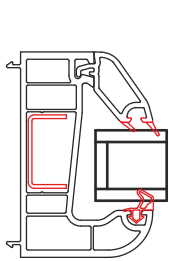

B-B

Window Sections

70 Sliding Fix Profile Application

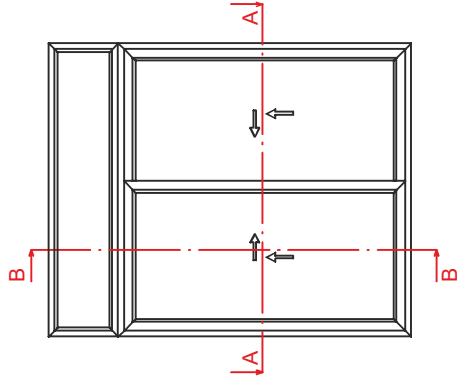

A-A

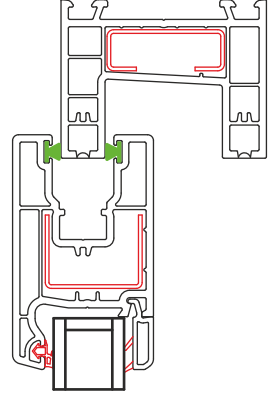
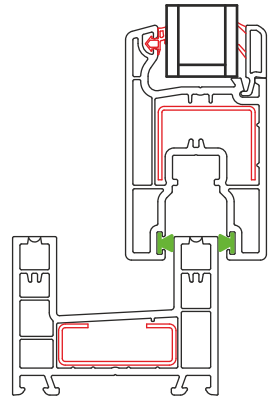
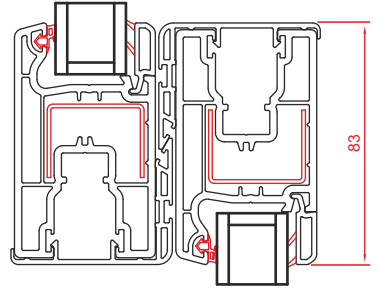
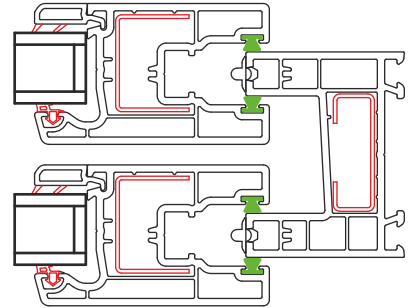

SLIDING SYSTEMS 70-75

Window Sections

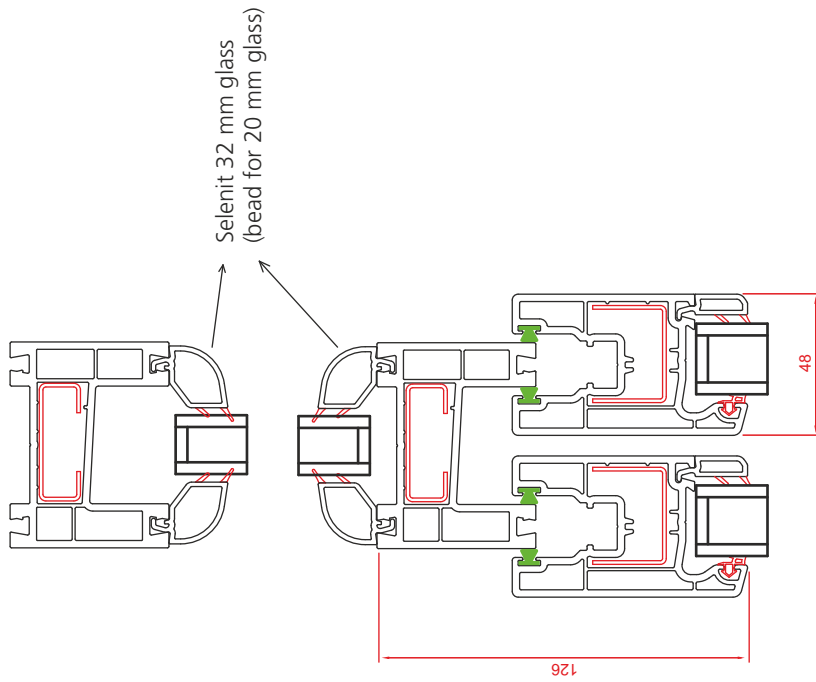

70 Sliding Mullion-Frame Application

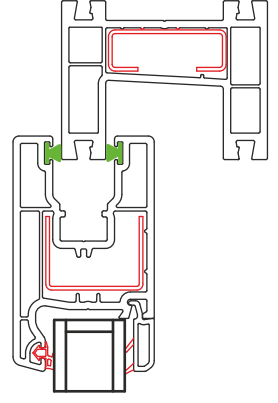
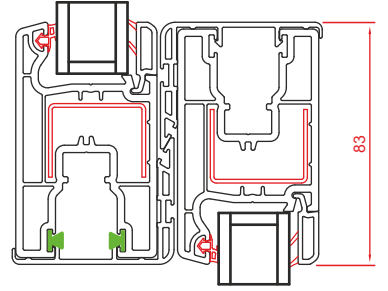
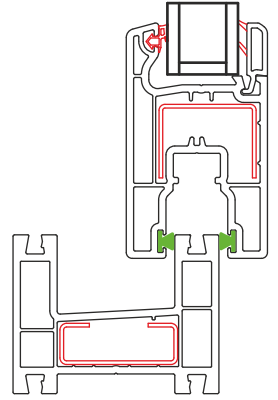
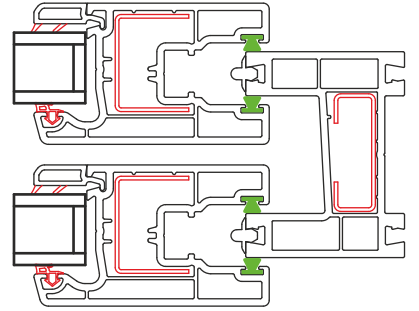
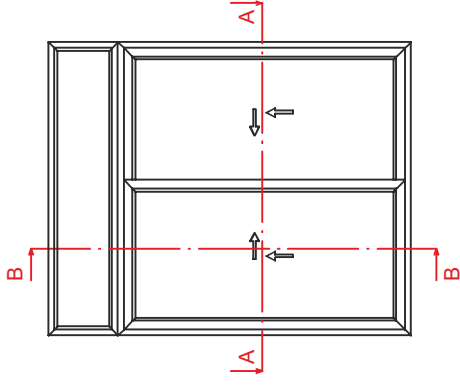

SLIDING SYSTEMS 70-75

Window Sections

75 Sliding Insulated Frame Application

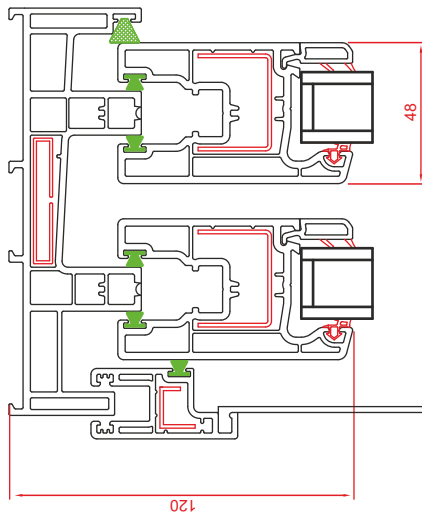

B-B

Sash Cutting Measurement	Vertical		Horizontal	
	Measurement (mm)	Pieces	Measurement (mm)	Pieces
	A-68	4	$(B/2)+8$	4

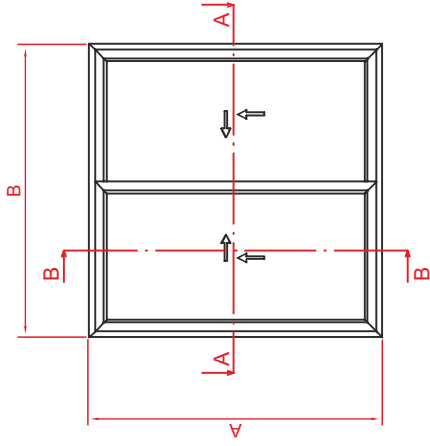

A-A

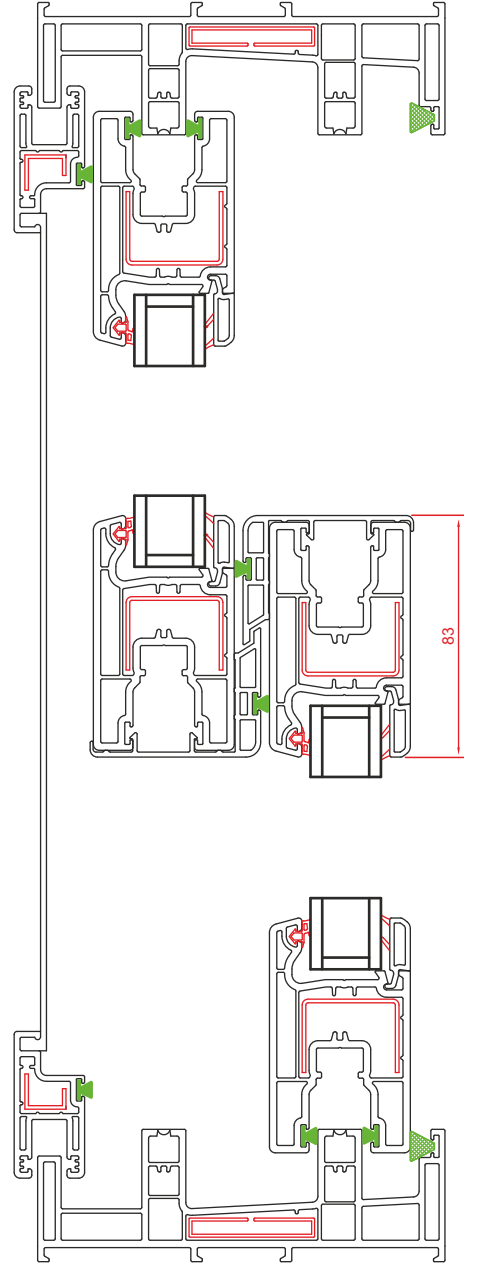

SLIDING SYSTEMS 70-75

Window Sections

Fly Screen Frame Application

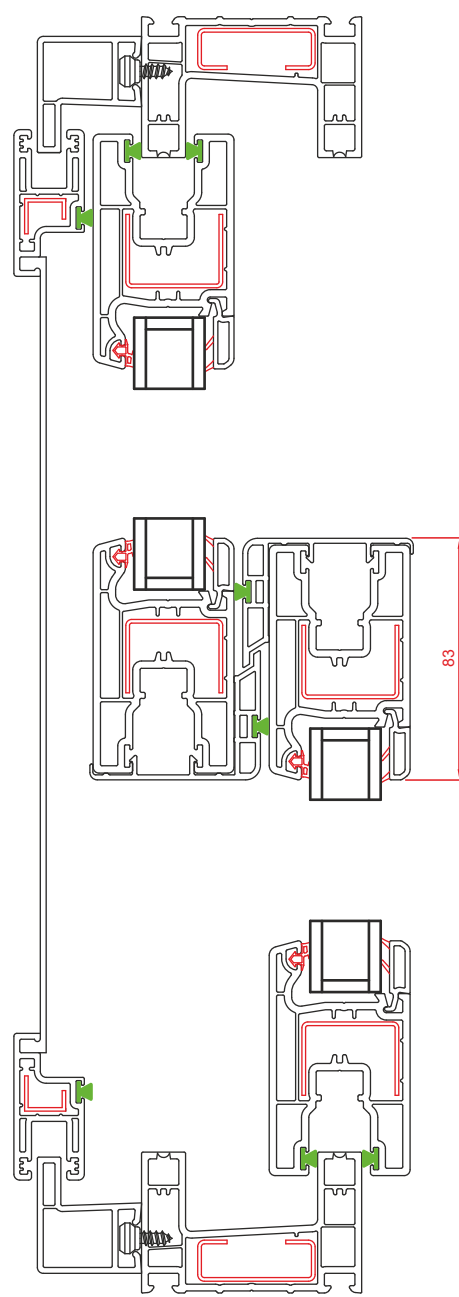
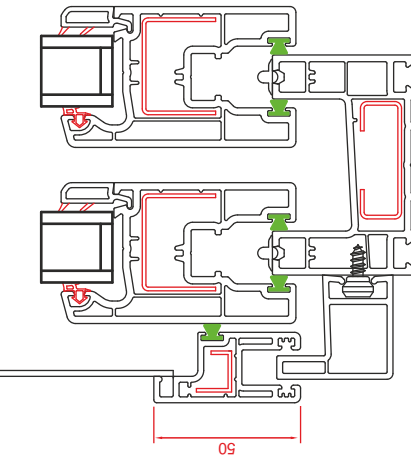
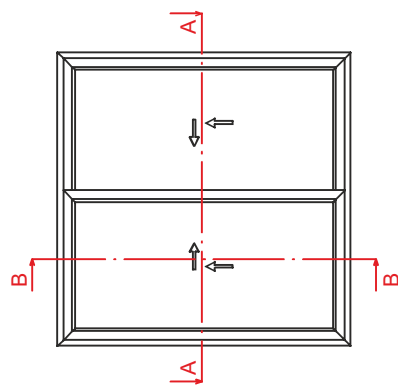
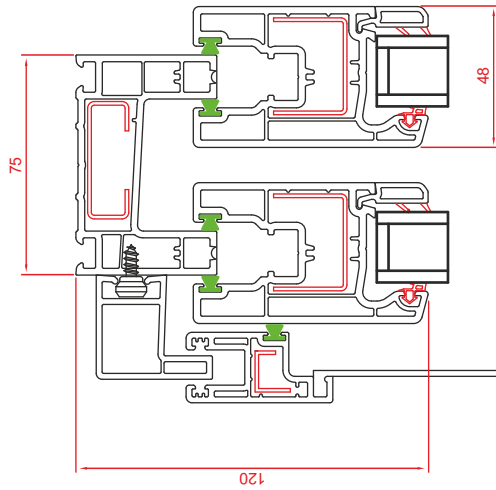

SLIDING SYSTEMS 70-75

Window Sections

70 Sliding Aluminium Sash Closing Application

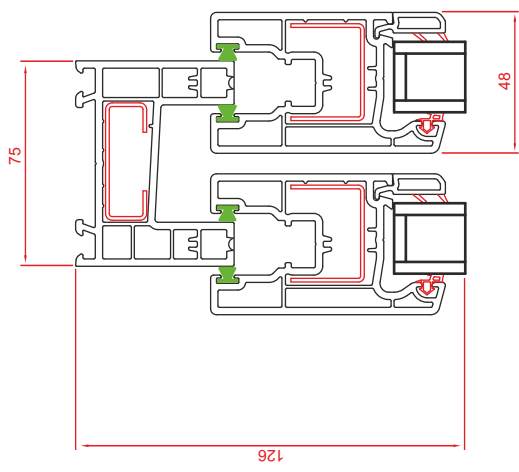

B-B

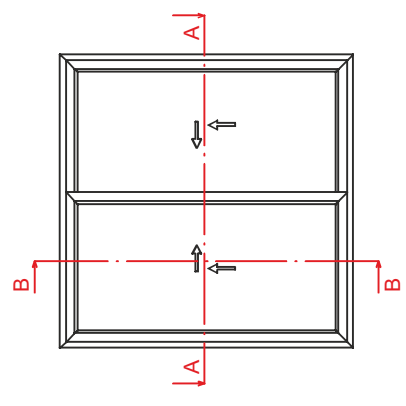

A-A

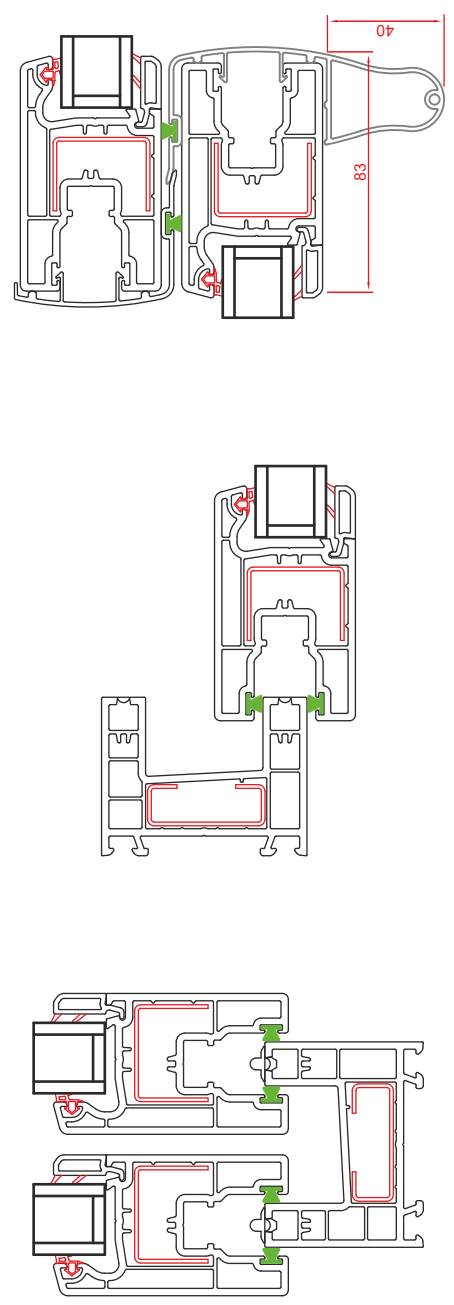

SLIDING SYSTEMS 70-75

Window Sections

75 Sliding Aluminium Sash Closing Application

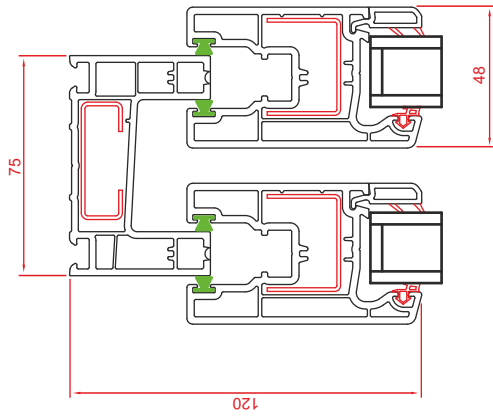

B-B

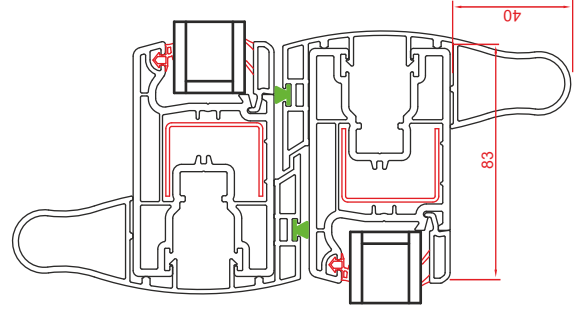
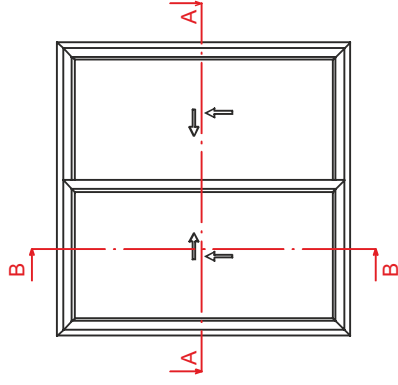

A-A

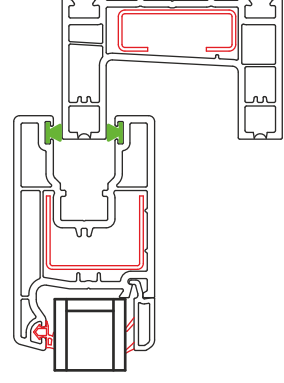
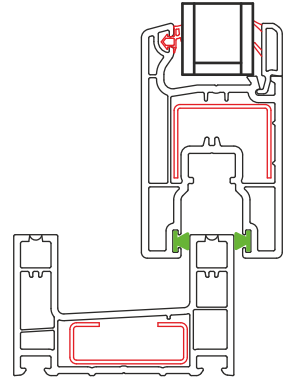
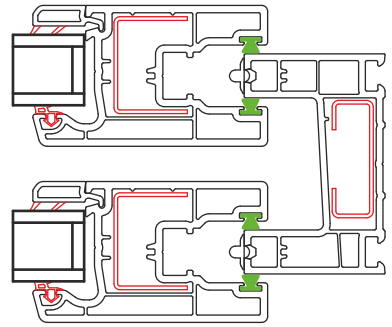

SLIDING SYSTEMS 70-75

Window Sections

70 Sliding Aluminum Threshold Application

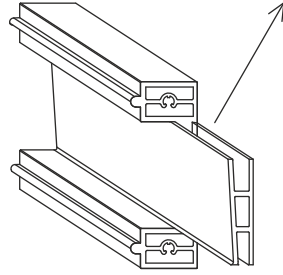
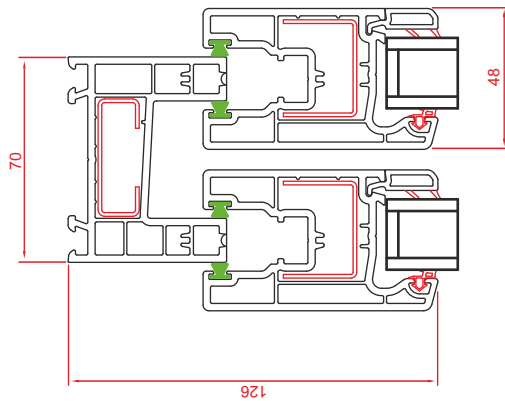

The leg sections of the aluminum frame is skived 25mm.

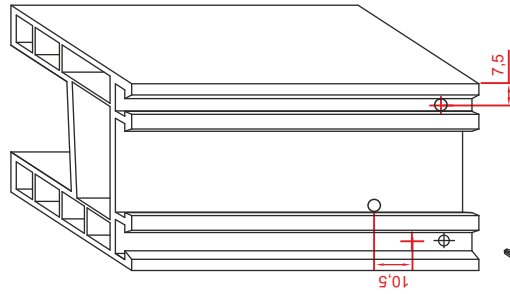

B-B

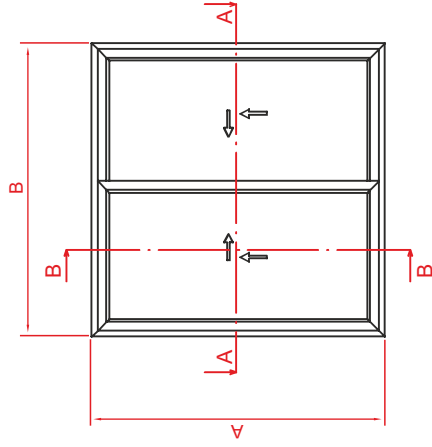

Vertical		Horizontal	
Measurement (mm)	Pieces	Measurement (mm)	Pieces
A-53	4	(B/2)	4
Sash Cutting Measurement			

It's joined with 4.2 x 60 mm size drilling screws, by the screw holes from the back of the aluminium frame.

A-A

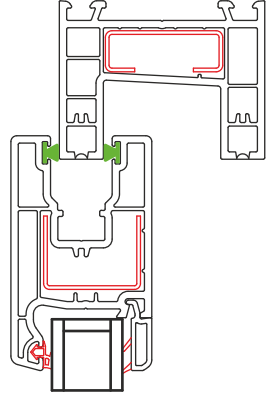
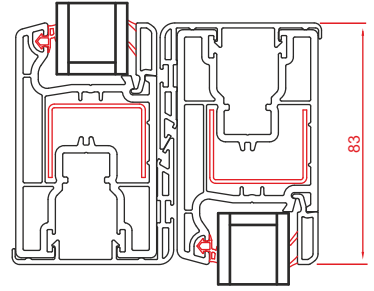
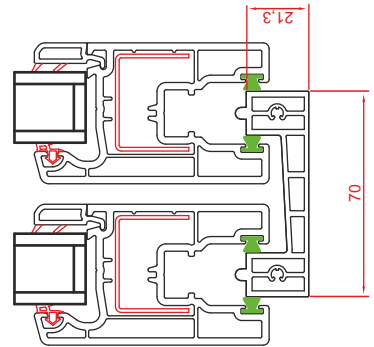

Sliding Aluminium Corner Frame Application

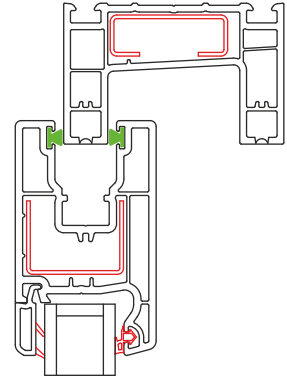
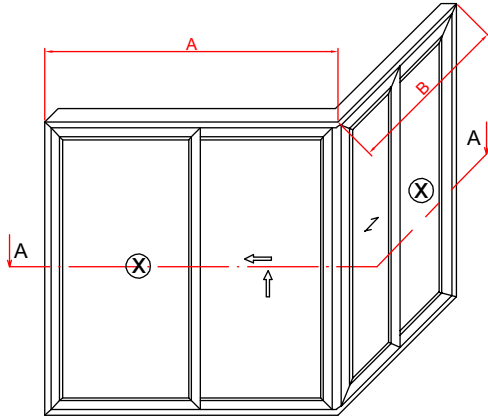

For 75 Sliding Frame

	Vertical		Horizontal	
	Measurement (mm)	Pieces	Measurement (mm)	Pieces
Sash Cutting Measurement	A-74	8	$(B/2)+2$	8

For 70 Sliding Frame

	Vertical		Horizontal	
	Measurement (mm)	Pieces	Measurement (mm)	Pieces
Sash Cutting Measurement	A-86	8	$(B/2)-1,5$	8

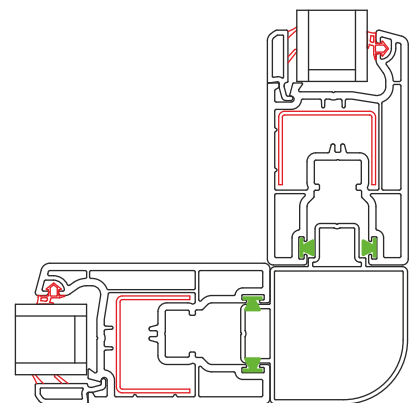
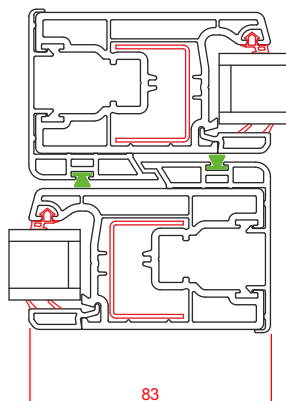
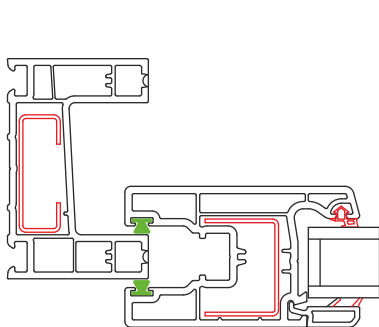
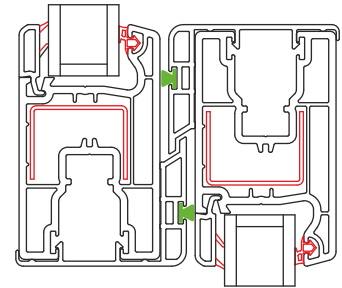

Sliding Sash Adapting Profile Application

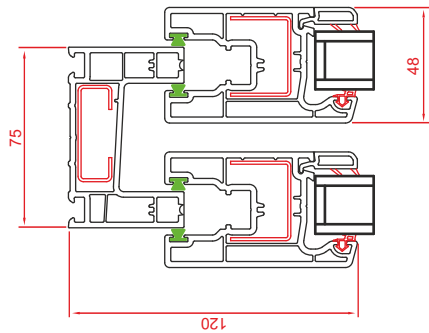

For 75 Sliding Frame

Sash Cutting Measurement	Vertical		Horizontal	
	Measurement (mm)	Pieces	Measurement (mm)	Pieces
A-74	8	8	$(B/4)+23$	8

For 70 Sliding Frame

Sash Cutting Measurement	Vertical		Horizontal	
	Measurement (mm)	Pieces	Measurement (mm)	Pieces
A-86	8	8	$(B/4)+20$	8

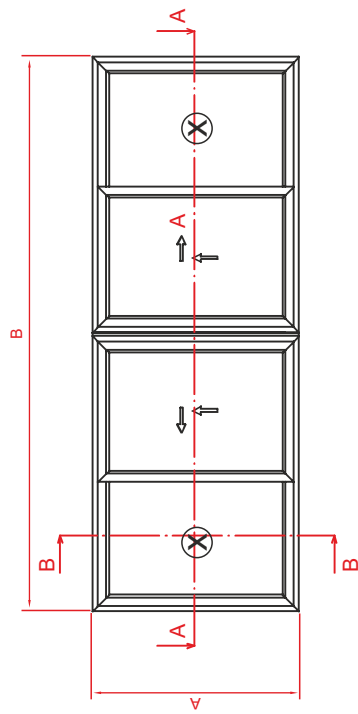

B-B

A-A

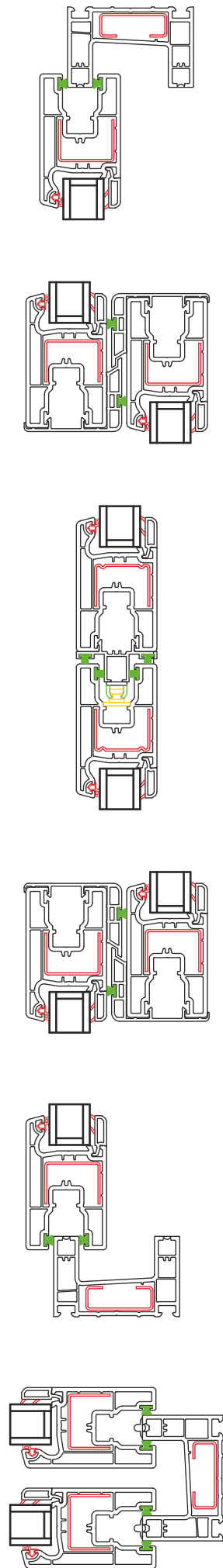

SLIDING SYSTEMS 70-75

Water Drain Channels

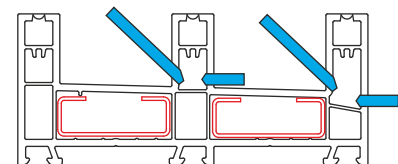
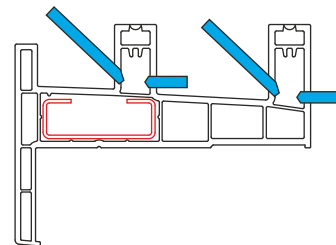
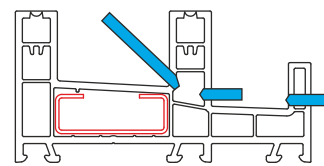
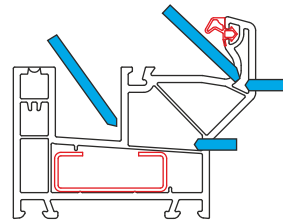
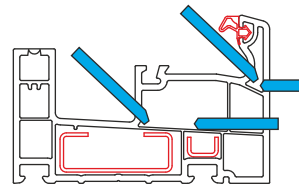
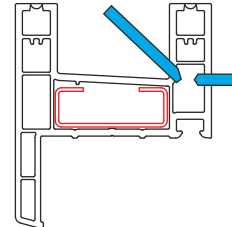
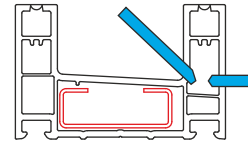
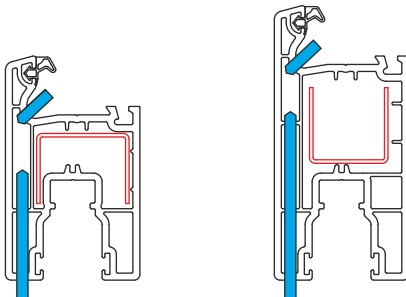
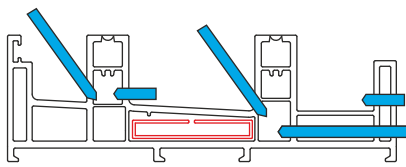
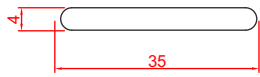
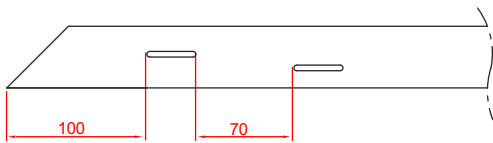
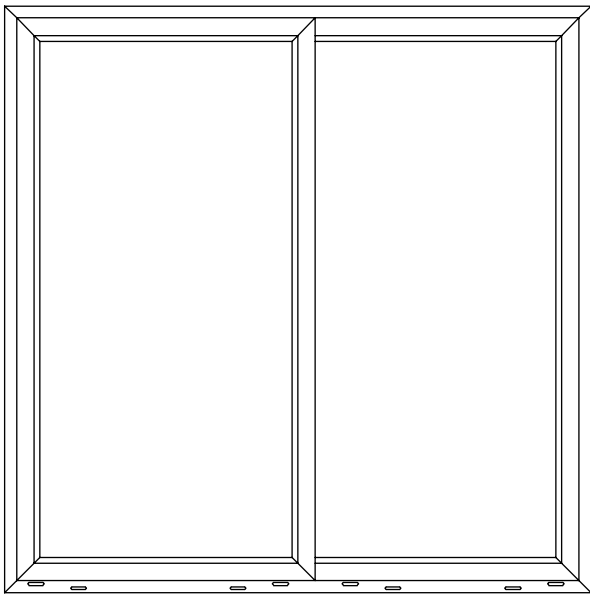

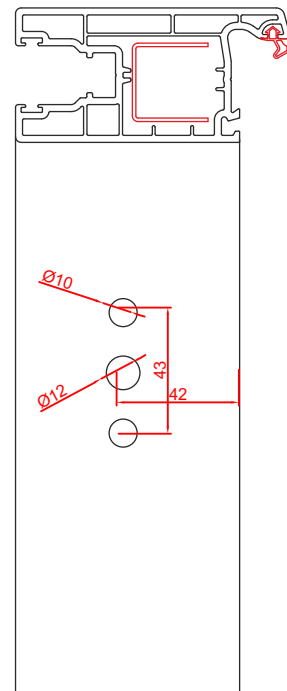
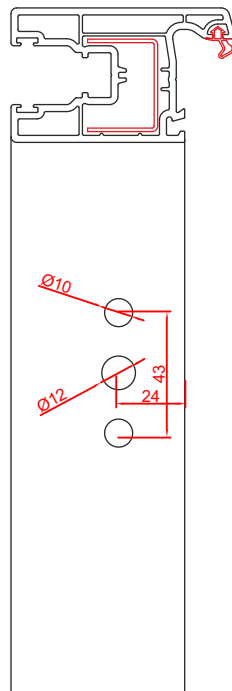
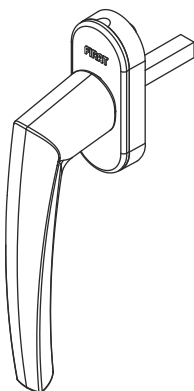
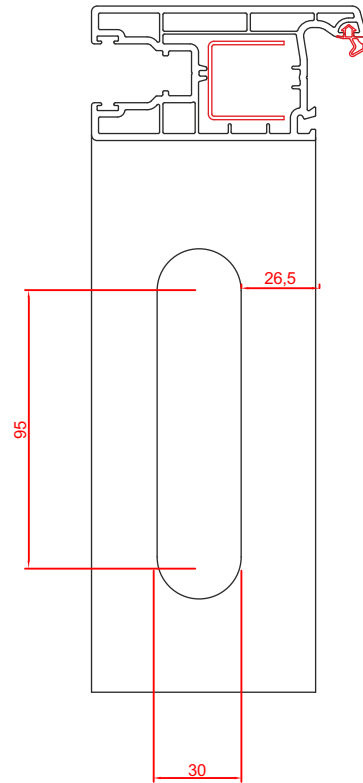
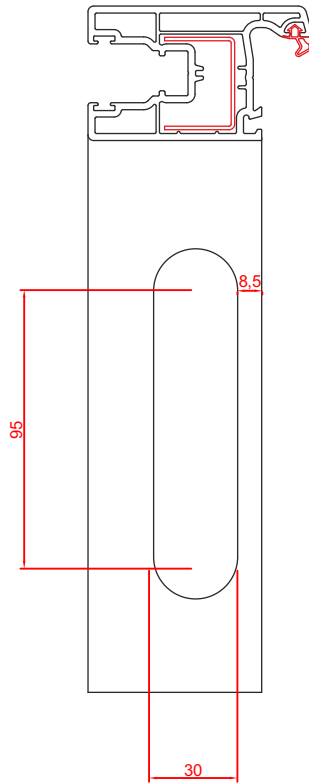
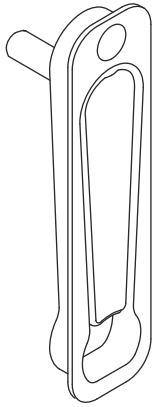

1. Profile cutting angle should be exactly 45°. Otherwise, welding weaknesses will occur because the surfaces to be welded cannot fully meet each other.
2. Welding machine plate surfaces should be smooth and in balance.
3. Resistance teflones must be clean and not torn.
4. Weld surfaces should not have profile shavings and surfaces should be clean
5. Welding resistance temperature should be in the range of 230 - 250 °C.
6. Welding resistance temperature should be in the range of 230 - 250 °C.
7. Vertical piston pressures should be 6 bar, melt pressure (when there is resistance) should be 3 bar and welding pressure should be 6 bar.

In order to perform a welding process in accordance with the standards, the following welding molds must be used during the welding process;

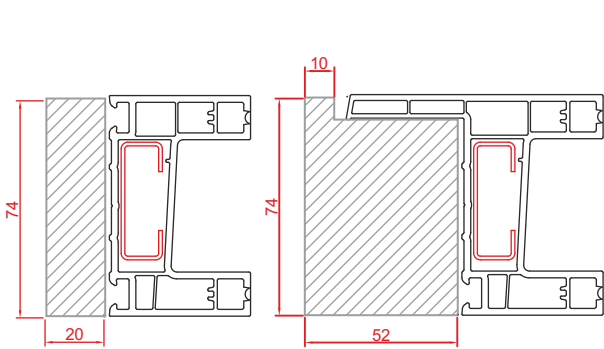

75 Sliding Frame

75 Sliding Frame With Architrave

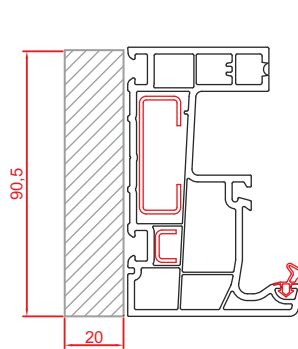

75 Sliding Fix Frame

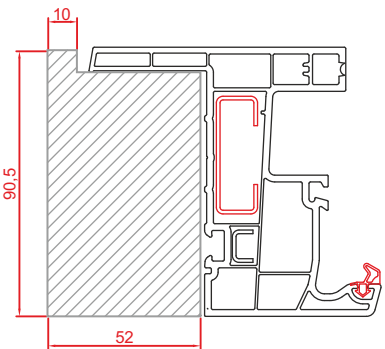

75 Sliding Fix Frame With Architrave

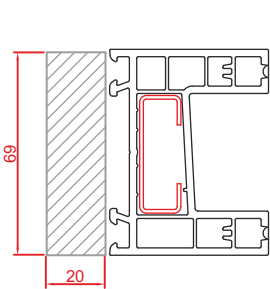

70 Sliding Frame

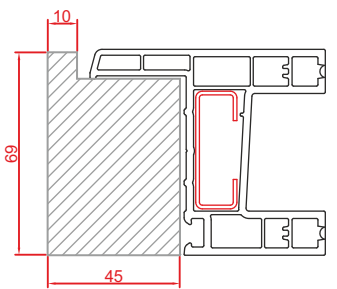

70 Sliding Frame With Architrave

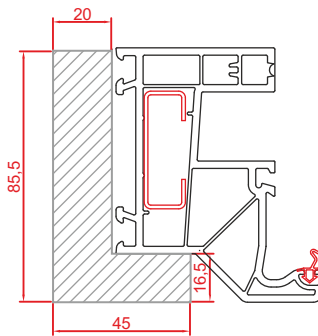

70 Sliding Fix Frame

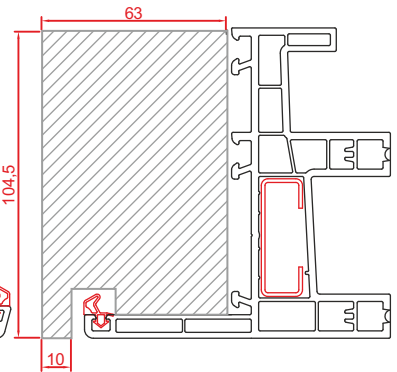

Sliding Frame With Outside Flyscreen & 50 mm Architrave

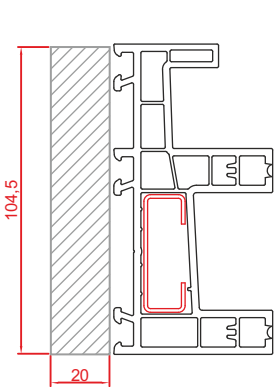

70 Sliding Frame With Fly Screen

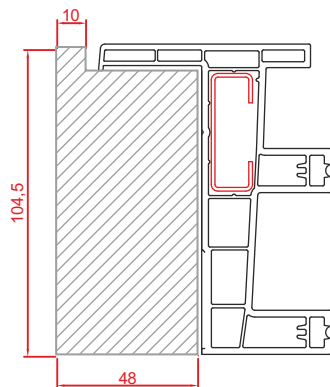

70 Sliding Frame With Inside Fly Screen & Architrave

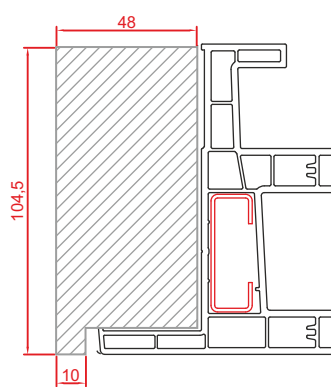

70 Sliding Frame With Outside Fly Screen & Architrave

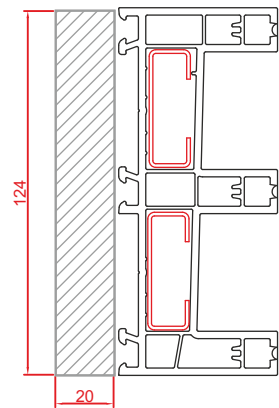

Three Track Sliding Frame

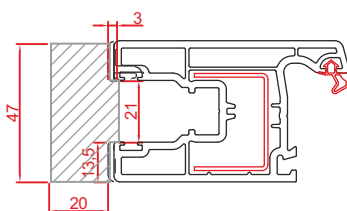

Sliding Sash Profile

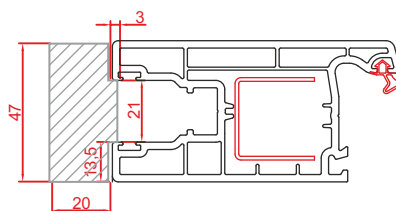

Sliding Door Sash Profile

FIRAT

Türkoba Mah. Fırat Plastik Cad. No: 23
34537 Büyükçekmece - İstanbul - TÜRKİYE
T: +90 (212) 866 41 41 - 866 42 42
F: +90 (212) 04 00 - 859 05 00

Customer Service:

+90 444 9 378 (FRT) / +90 800 219 80 20

firat@firat.com - info@firat.com
info@firatpen.com.tr - musterihizmetleri@firat.com
www.firat.com - www.firatpen.com.tr

📷 / Fıratplastiktr 📧 / Fıratplastik 📞 / Fıratplastik 🌐 / Fıratplastik
📷 / Fıratpentr 📧 / Fıratpen 📞 / Fıratpentr